

CALIFORNIA PUSH-PULL, INC.

6TH EDITION

QUADRASTAT

Cablecraft.

PUSH PULL PULL ONLY CLUTCH & BRAKE CABLES

CONTROL HEADS

twist lock
non locking
micro adjust

CONTROL LEVERS

SPOOL VALVE ADAPTORS

CONTROL CABLES

ACCESSORIES

clevises
eye ends
clamps
etc.

FLEXIBLE
SMOOTH OPERATION
RUGGED
RELIABLE

100%
LOAD
TESTED



Check us out on Facebook

SPECIALIZING IN REPLACEMENT AND CUSTOM BUILT CABLES

3 COMMERCE CT., STE. 130 · CHICO, CA 95928

530-893-4060 Fax 530-893-4062

Website: <http://www.push-pull.com> • E-mail: sales@push-pull.com

Locally Assembled Cable Controls with Threaded or Grooved Conduit End Fittings

Part Number Code

SAMPLE PART NO. 173-MTG-2-90

Construction

- 173—Utility with stainless end rods.
- 174—Marine utility with stainless end rods, stainless support tube and stainless armor inner member.
- 183—Low Friction with teflon and nylon wear surfaces and stainless steel end rods.
- 184—Marine Low Friction with teflon and nylon wear surfaces, stainless steel end rods, stainless steel swivel support tubes and stainless steel inner member.

Duty (load carrying capacity)

Available in: V (Very light duty), L (Light duty), M (Medium duty), H (Heavy duty). Determine by load or end rod diameter from table A below.

Conduit End Fittings

TT (Threaded fittings both ends), GG (Grooved fittings both ends), TG (Threaded fitting one end and Grooved on the other). See table A and diagram B below for dimensions.

Length of Travel

1 to 6 inches. Determine from table A and diagram C below.

Length Overall (in inches)

A Duty Load capacities and length of travel

Basic Part Number	Thread "F"	Min. Bend Radius Inches	Pull Load Capacity All travels Pounds	Push Load Capacity for Travel Shown in pounds						Thread "W"	Dimension "A" for Travel Shown in inches						Groove Dimension		Dimension "A" for Travel Shown in inches					
				1"	2"	3"	4"	5"	6"		1"	2"	3"	4"	5"	6"	Radius Inches	Root Diam. Inches	1"	2"	3"	4"	5"	6"
V	10-32 x 0.89	2	120	80	70	60	45	30	7/16-20 x 1.12"	4.38	5.87	7.38	8.87	10.38	11.87	.13 (width)	.25	3.69	5.19	6.69	8.19	9.69	11.13	
L	1/4-28 x 1.00	3	230	150	125	100	75	50	5/8-18 x 1.50"	4.62	6.12	7.62	9.12	10.62	12.12	.17	.41	4.00	5.50	7.00	8.50	10.00	11.50	
M	5/16-24 x 1.19	5	400	250	210	170	130	100	11/16-16 x 1.75"	5.06	6.56	8.06	9.56	11.06	12.56	.17	.47	4.33	5.87	7.38	8.87	10.38	11.87	
H	3/8-24 x 1.38	6	1,000	700	600	500	400	300	7/8-14 x 2.00"	5.89	7.19	8.89	10.19	11.69	13.19	.20	.50	5.19	6.69	8.19	9.69	11.19	12.69	

MM conversions: 1 inch = 25.4 mm. 1 mm. = .03937 inches. 1 lb. = .4536 kg. 1 kg. = 2.2046 lbs.

B Conduit End Fittings

Type T

Threaded Conduit End Fitting for bulkhead mounting

Type G

Grooved Conduit End Fitting for mounting with U-bolts or clamps.

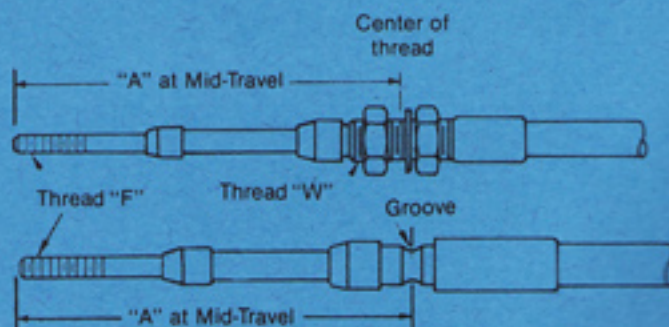

C Overall length and travel in inches

FOR REPLACEMENT CABLES

- A. Remove old cable.
- B. Measure length as shown below.
- C. Measure length of travel. 1" through 6".
- D. Determine size of thread "F."
Select basic part number from Table above.

FOR NEW CABLES

- A. Determine overall length.
- B. Measure travel required. Add 1/4" and then round upward to nearest whole inch.
- C. Determine loads and select Basic part number from Table A.

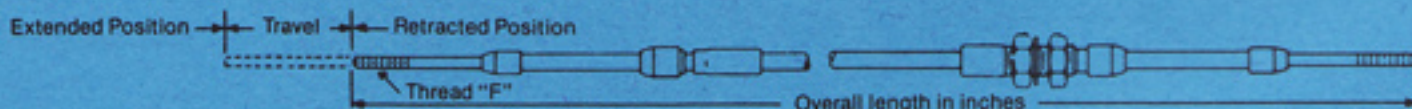

Standard Push-Pull Cable Terminology

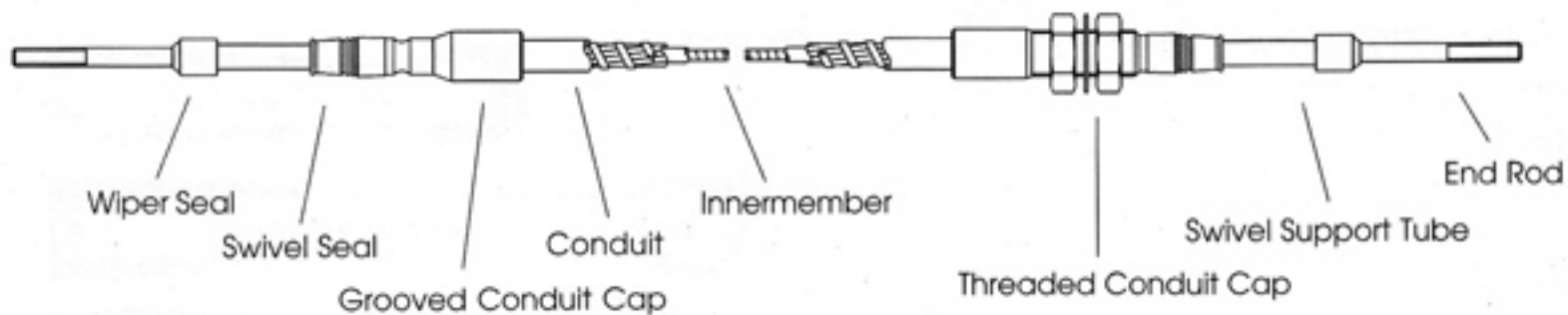

How to Identify Push-Pull Cables

Your goal is to determine the information required to make up the "ordering code" or part number. An example of a typical ordering code is 173-VTG-3-144.

173 - V TG - 3 - 144

- Step 1: Determine the "duty" (size) of the cable by the diameter and threads of the end rods. **V** = 10-32, **L** = 1/4-28, **M** = 5/16-24, **H** = 3/8-24.
(Very light duty; Light duty; Medium duty; Heavy duty)
- Step 2: Determine the type of **conduit end** fittings (conduit caps) for left end and right end. **T** = Threaded, **G** = Grooved. TT, GG or TG combinations.
- Step 3: Determine the **travel** of the end rod. 1" through 6" in one inch increments.

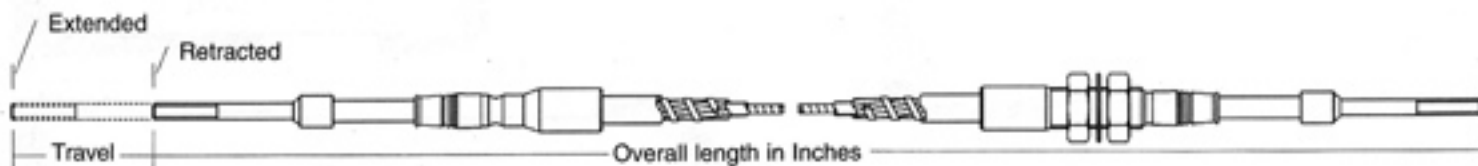

- Step 4: Determine the overall **length** of the cable.
- Step 5: Determine cable materials depending on usage and conditions.
See details of 173, 174, 175 Utility and 313, 314, 315 Low-Friction EXT.

Utility: "The Rugged Gray Cable," is the industry standard and is designed for a long life under rugged conditions (173, 174, 175).

Low-Friction - EXT: "The Green Cable," is the proper cable to use when superior efficiency is required. The extruded nylon cover over the innermember works extremely smoothly with the poly liner (313, 314, 315).

(See "Specifications" on page 4 and "Ordering Code" on page 5 to determine part number)

Visual Comparison Chart for Determining Travel

To determine the "travel" on an existing cable, you can compare the length of the support tubes with the illustrations below and on the next page.

Determine the "duty" (size) of the cable by the diameter and threads of the end rods.

V = 10-32, L = 1/4-28, M = 5/16-24, H = 3/8-24.

(Very light duty; Light duty; Medium; Heavy)

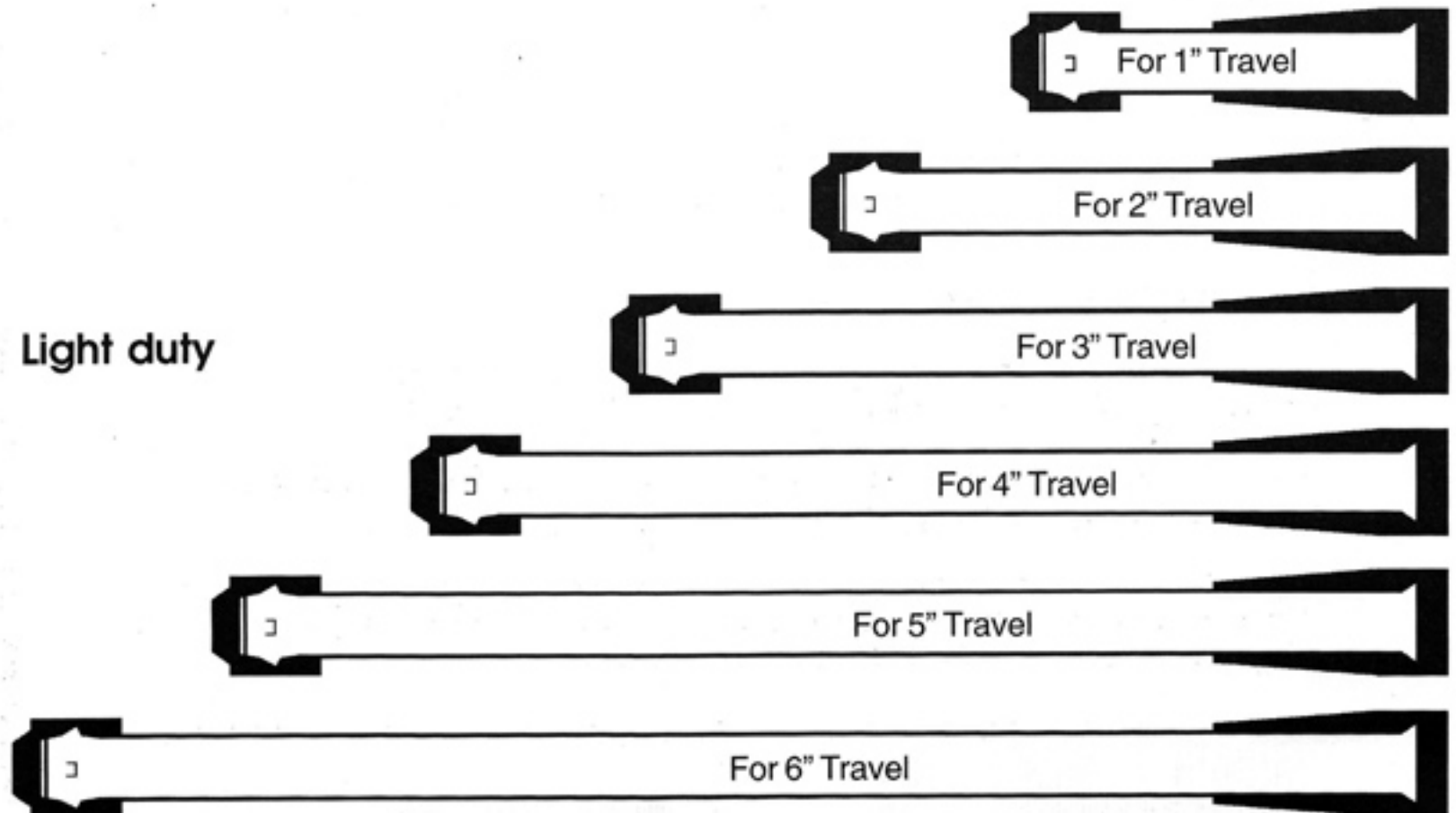
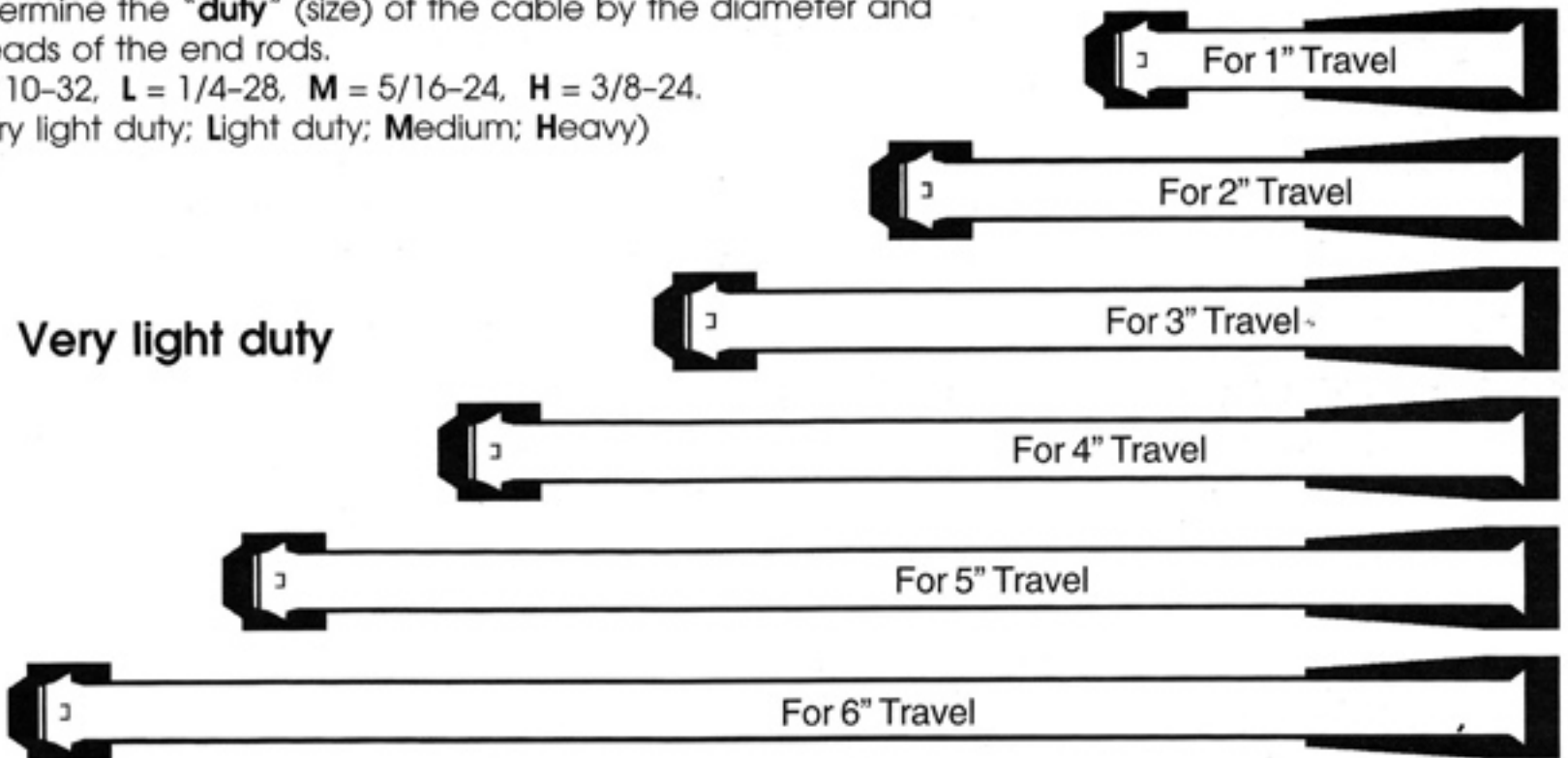

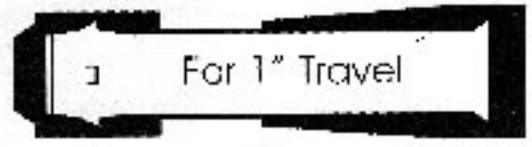

For 1" Travel

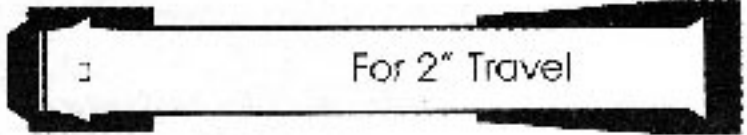

For 2" Travel

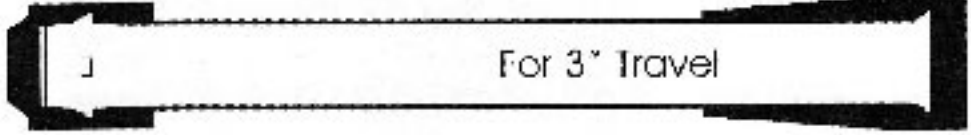

For 3" Travel

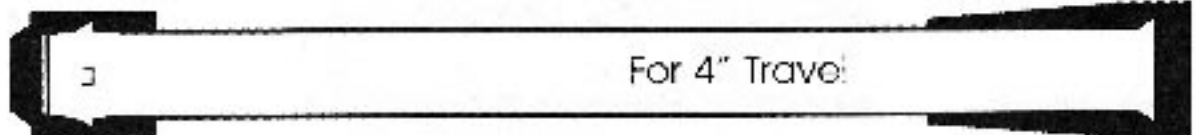

For 4" Travel

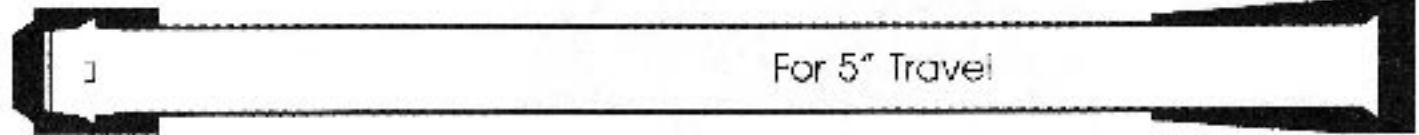

For 5" Travel

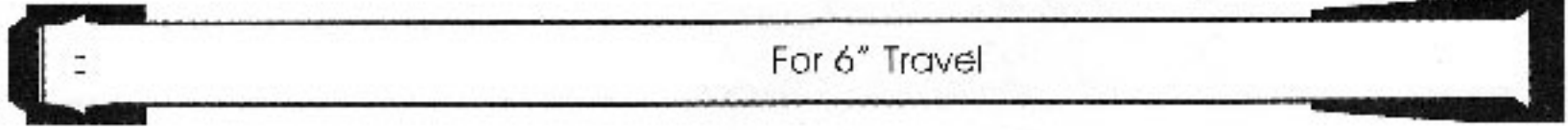

For 6" Travel

Medium duty

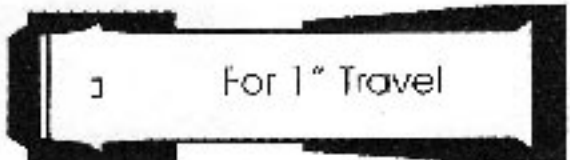

For 1" Travel

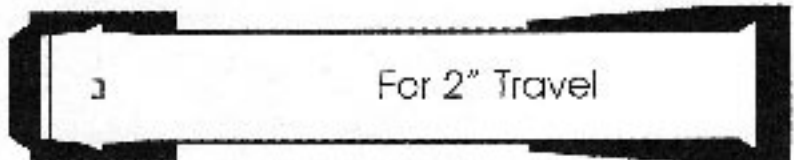

For 2" Travel

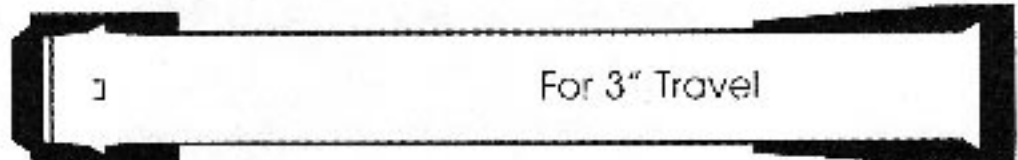

For 3" Travel

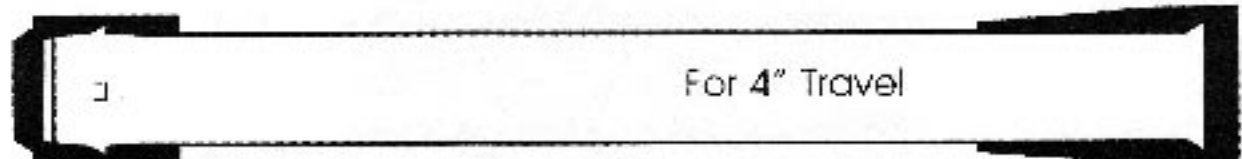

For 4" Travel

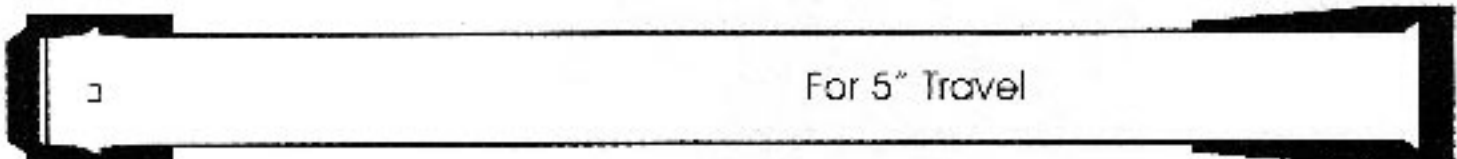

For 5" Travel

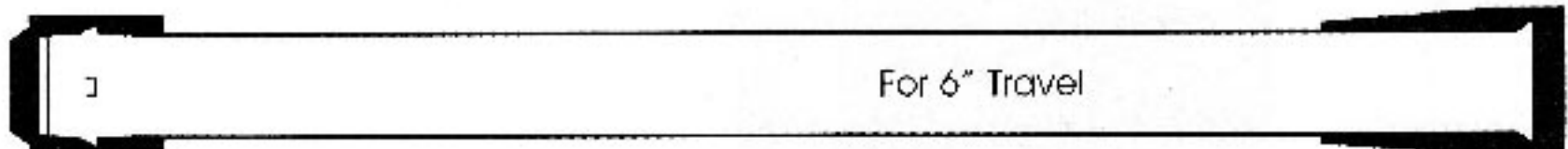

For 6" Travel

Heavy duty

UTILITY CONTROLS

THREADED SWIVEL CONDUIT FITTING

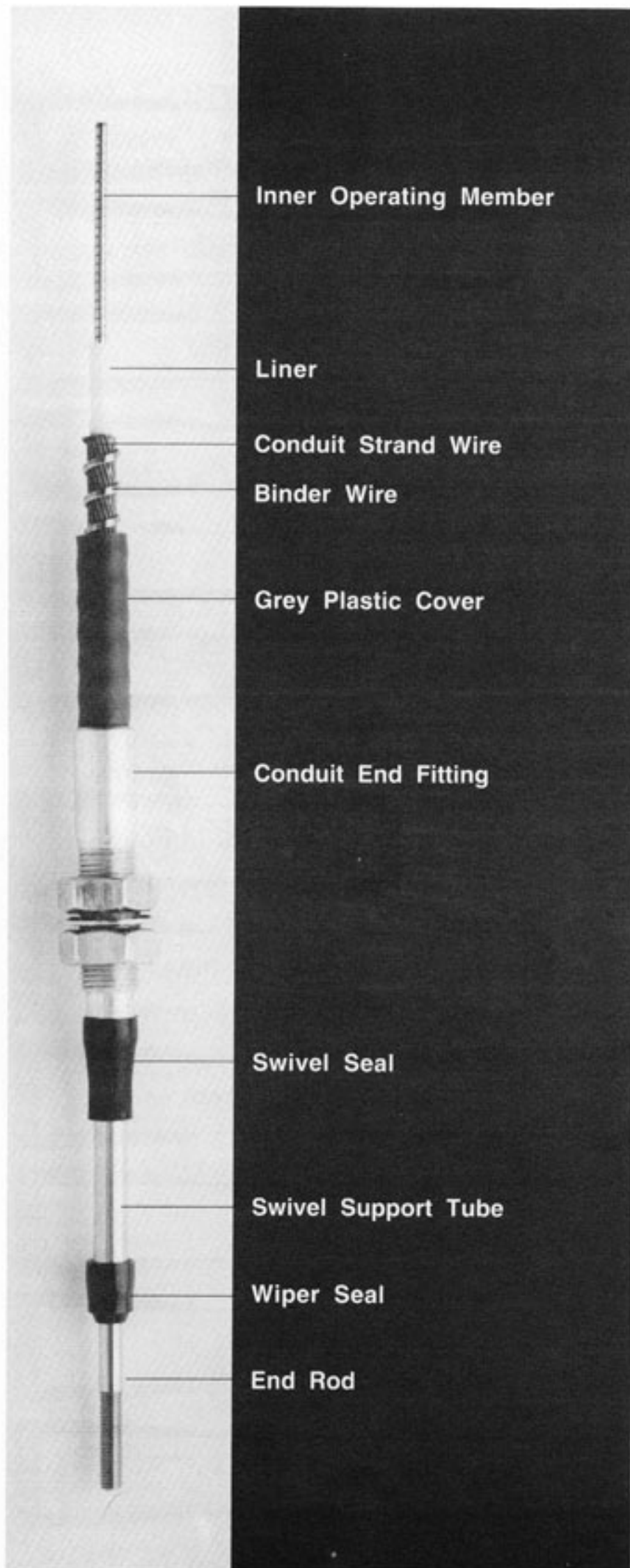
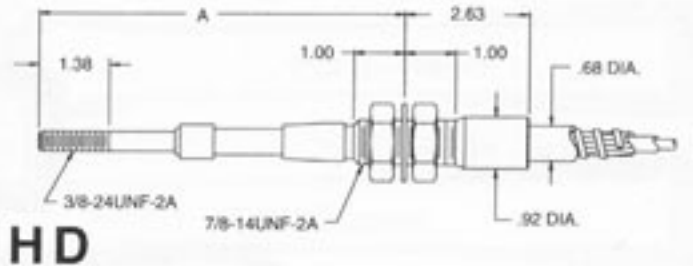
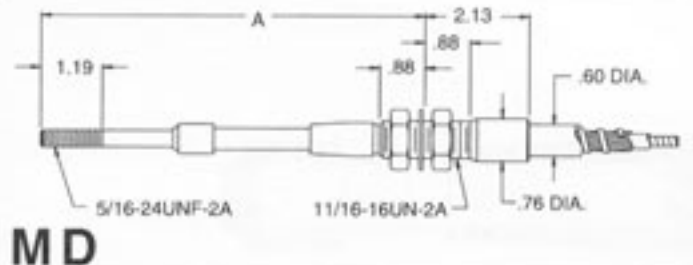
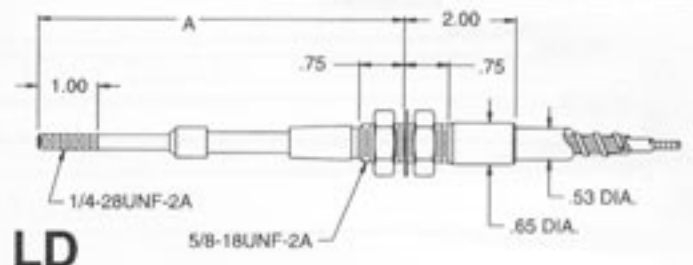
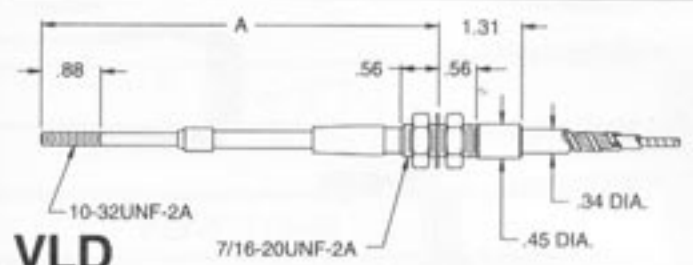

- Greater flexibility
- High strength
- Wide temperature capability
-65° to +230° F.

DESIGN CRITERIA

DUTY	MINIMUM BEND RAD.	BACKLASH FACTOR Note (1)	EFFICIENCY FACTOR
VLD	2"	.00015	.002
LD	3"	.00020	See formula below Note (2)
MD	5"	.00025	
HD	6"	.00030	

(1) Per degree of bend

(2) Input force = output load (lbs) x total degrees of bend x efficiency factor + output load (lbs)

'A' DIMENSION THREADED SWIVEL (Control at mid-travel)	MINIMUM TRAVEL	WORKING INPUT LOAD Push/Pull	MAXIMUM INPUT OVERLOAD Push/Pull	'A' DIMENSION GROOVED SWIVEL (Control at mid-travel)
--	-------------------	---------------------------------------	---	---

4.38	1"	80/120	120/180	3.69
5.87	2"	80/120	120/180	5.19
7.38	3"	70/120	110/180	6.69
8.87	4"	60/120	90/180	8.19
10.38	5"	45/120	70/180	9.69
11.87	6"	30/120	45/180	11.19

4.62	1"	150/230	230/350	4.00
6.12	2"	150/230	230/350	5.50
7.62	3"	125/230	190/350	7.00
9.12	4"	100/230	150/350	8.50
10.62	5"	75/230	110/350	10.00
12.12	6"	50/230	75/350	11.50

5.06	1"	250/400	400/600	4.38
6.56	2"	250/400	400/600	5.87
8.06	3"	210/400	300/600	7.38
9.56	4"	170/400	250/600	8.87
11.06	5"	130/400	200/600	10.38
12.56	6"	100/400	150/600	11.87

5.69	1"	700/1000	1000/1500	5.19
7.19	2"	700/1000	1000/1500	6.69
8.69	3"	600/1000	900/1500	8.19
10.19	4"	500/1000	750/1500	9.69
11.69	5"	400/1000	600/1500	11.19
13.19	6"	300/1000	450/1500	12.69

GROOVED SWIVEL CONDUIT FITTING

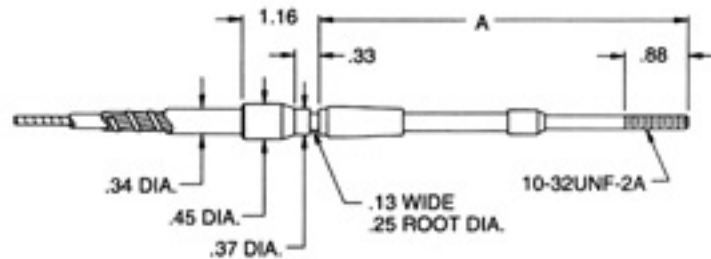

VLD

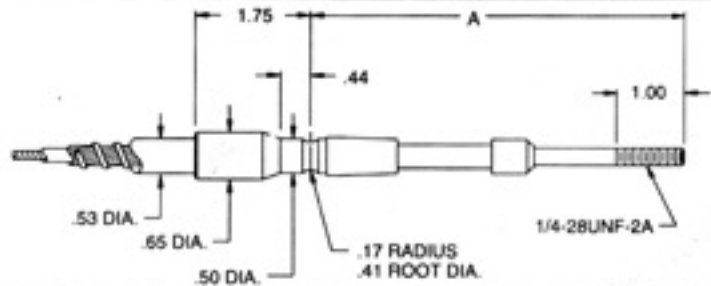

LD

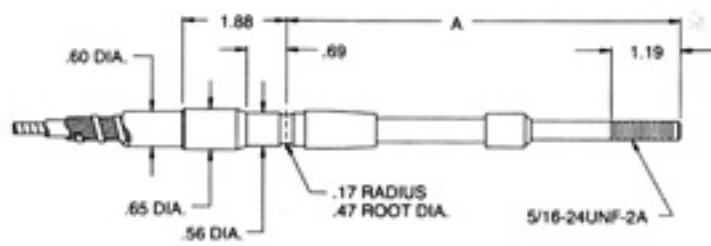

MD

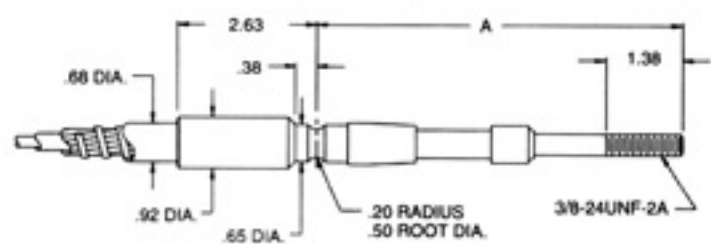

HD



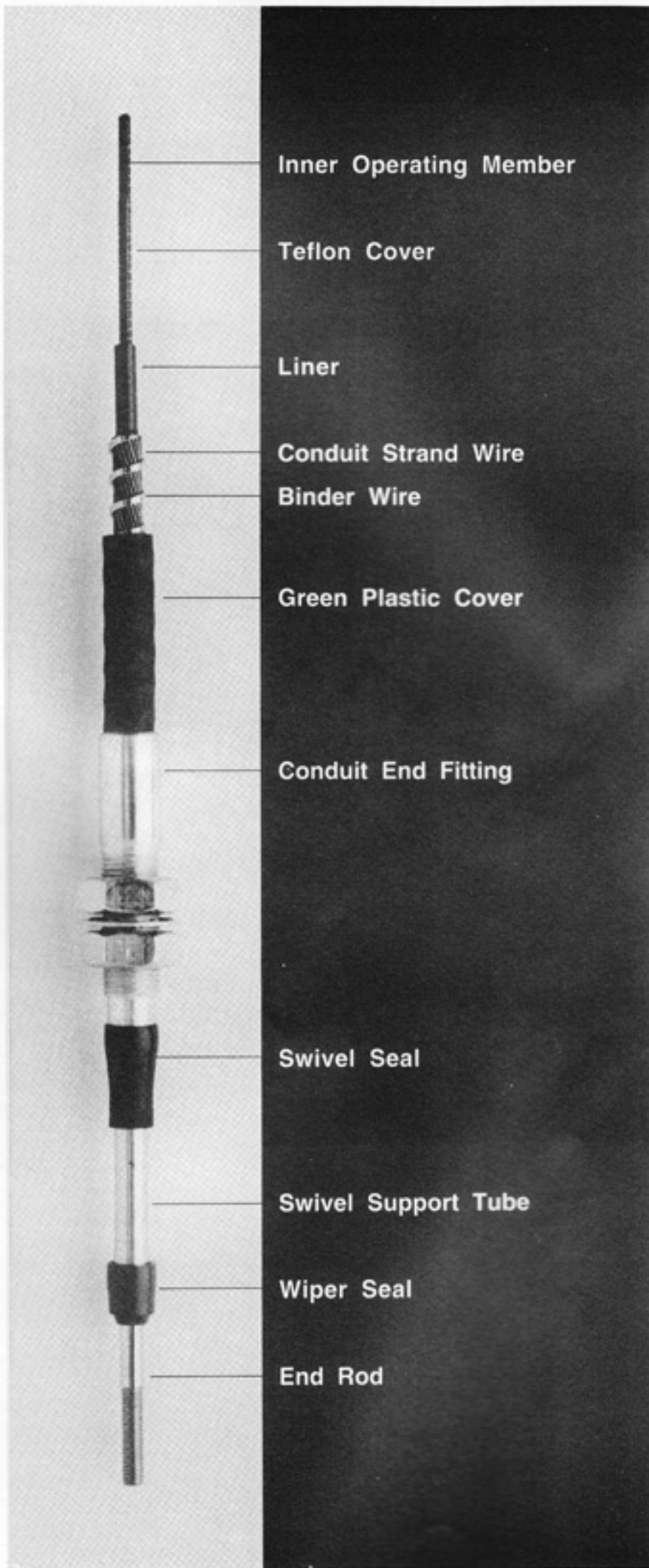

Inner Operating Member

Teflon Cover

Liner

Conduit Strand Wire
Binder Wire

Green Plastic Cover

Conduit End Fitting

Swivel Seal

Swivel Support Tube

Wiper Seal

End Rod

LOW FRICTION CONTROLS

THREADED SWIVEL CONDUIT FITTING

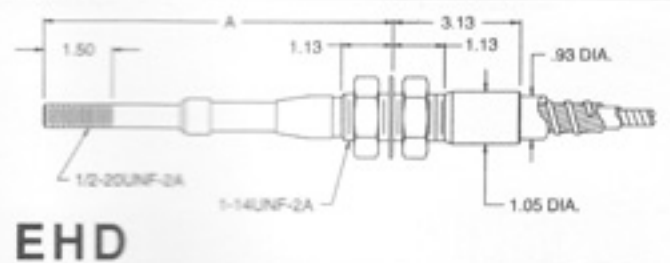
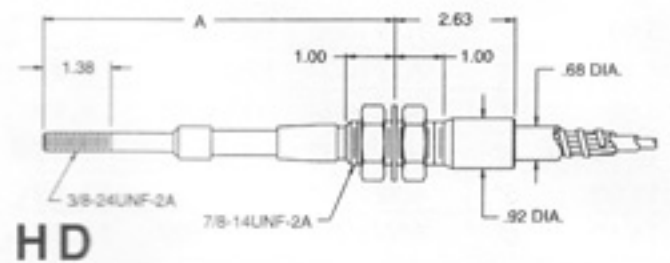
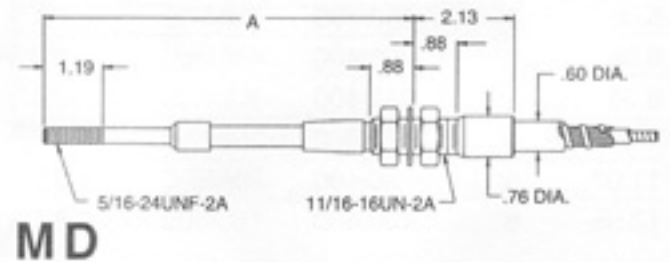
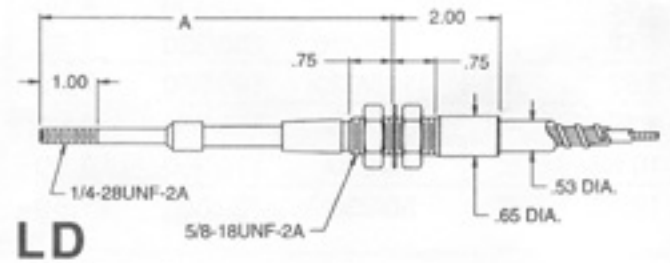
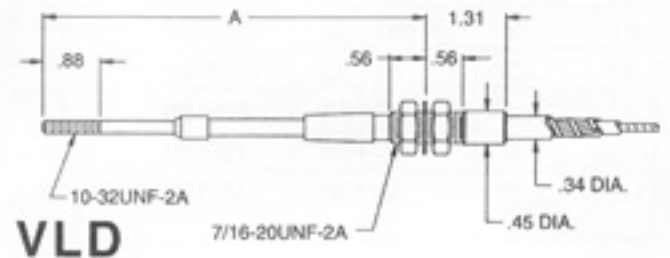

- Superior efficiency
- Greater flexibility
- High strength
- Widest temperature capability
-65° to +310° F.

DESIGN CRITERIA

DUTY	MINIMUM BEND RAD.	BACKLASH FACTOR Note (1)	EFFICIENCY FACTOR
VLD	2"	.00015	.001
LD	3"	.00020	See formula below Note (2)
MD	5"	.00025	
HD	6"	.00030	
EHD	8"	.00035	

(1) Per degree of bend

(2) Input force = output load (lbs) x total degrees of bend x efficiency factor + output load (lbs)

'A' DIMENSION THREADED SWIVEL (Control at mid-travel)	MINIMUM TRAVEL	WORKING INPUT LOAD Push/Pull	MAXIMUM INPUT OVERLOAD Push/Pull	'A' DIMENSION GROOVED SWIVEL (Control at mid-travel)
--	-------------------	---------------------------------------	---	---

4.38	1"	80/120	120/180	3.69
5.87	2"	80/120	120/180	5.19
7.38	3"	70/120	110/180	6.69
8.87	4"	60/120	90/180	8.19
10.38	5"	45/120	70/180	9.69
11.87	6"	30/120	45/180	11.19

4.62	1"	150/230	230/350	4.00
6.12	2"	150/230	230/350	5.50
7.62	3"	125/230	190/350	7.00
9.12	4"	100/230	150/350	8.50
10.62	5"	75/230	110/350	10.00
12.12	6"	50/230	75/350	11.50

5.06	1"	250/400	400/600	4.38
6.56	2"	250/400	400/600	5.87
8.06	3"	210/400	300/600	7.38
9.56	4"	170/400	250/600	8.87
11.06	5"	130/400	200/600	10.38
12.56	6"	100/400	150/600	11.87

5.69	1"	700/1000	1000/1500	5.19
7.19	2"	700/1000	1000/1500	6.69
8.69	3"	600/1000	900/1500	8.19
10.19	4"	500/1000	750/1500	9.69
11.69	5"	400/1000	600/1500	11.19
13.19	6"	300/1000	450/1500	12.69

6.12	1"	1200/1500	1800/2200	5.50
7.62	2"	1200/1500	1800/2200	7.00
9.12	3"	1100/1500	1600/2200	8.50
10.62	4"	900/1500	1300/2200	10.00
12.12	5"	700/1500	1000/2200	11.50
13.62	6"	500/1500	750/2200	13.00

GROOVED SWIVEL CONDUIT FITTING

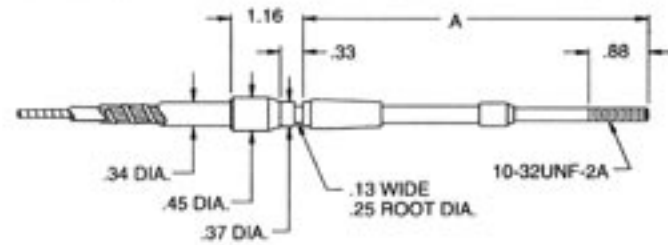

VLD

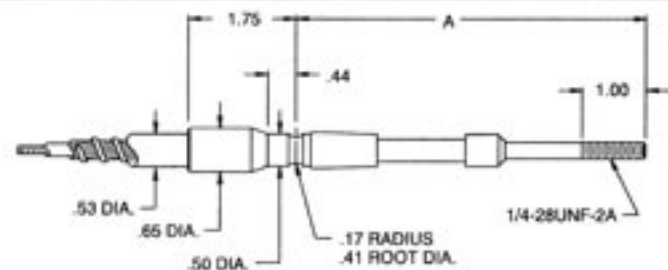

LD

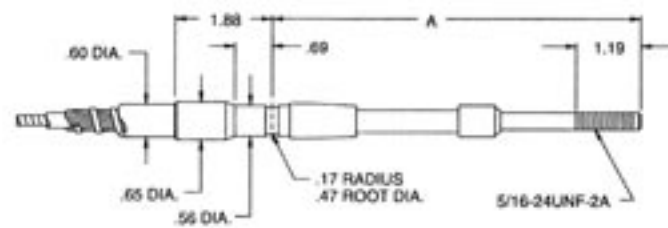

MD

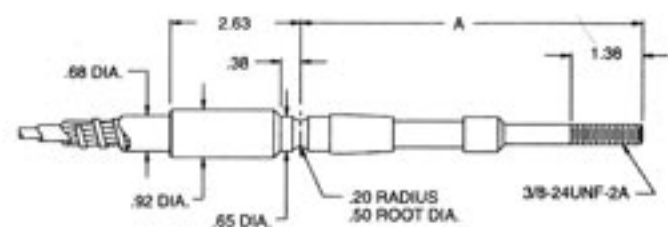

HD

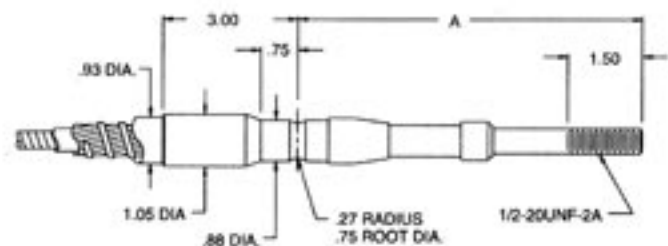

EHD



Push-Pull Cable Identification

Rod missing or bent/frozen on standard push-pull cable.

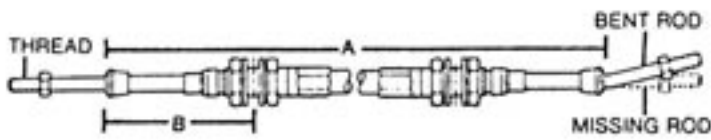

NOTE: Inspect and review the entire system to assure proper operation prior to installing a replacement cable.

Determine Series

The series can be determined by measuring the thread size on the remaining or good rod. (See Chart 1 below.)

SERIES	V	L	M	H
THREAD SIZE	#10-32	1/4-28	3/8-24	1/2-24
THREAD LENGTH	3/8" (22.2mm)	1" (25.4mm)	1 1/8" (30.2mm)	1 3/8" (35.0mm)
2X THREAD LENGTH	1 1/4" (44.5mm)	2" (50.8mm)	2 3/8" (60.3mm)	2 7/8" (69.9mm)

2. Determine Hub Configuration

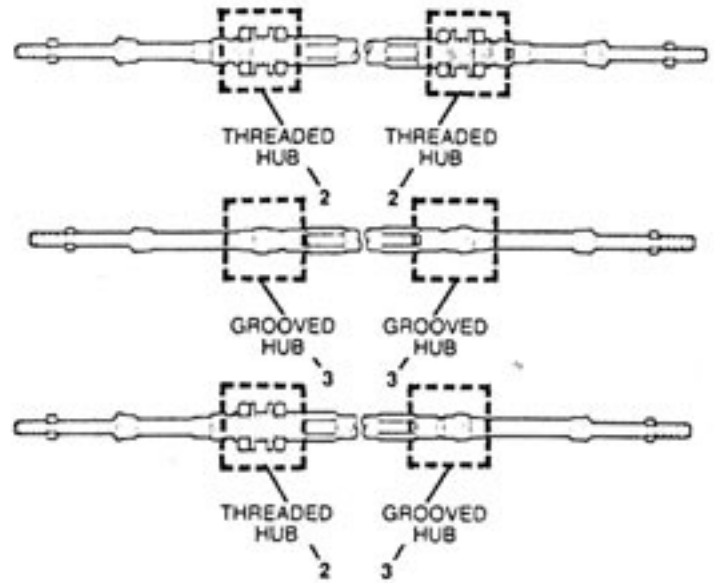

Determine Travel

Measure dimension "B". Locate the proper series and hub type on Chart 2, then follow across the chart to corresponding measure of dimension "B". Secure the proper travel at the top of the column (example: 3 series, threaded hub with a "B" dimension of 5 corresponds to a 3" travel).

CABLE SERIES	"B" DIMENSIONS BULKHEAD & CLAMP TYPE HUBS	HUB TYPE	"B" DIMENSION				
			1" TRAVEL	2" TRAVEL	3" TRAVEL	4" TRAVEL	5" TRAVEL
V		Threaded (2)	3" (76.2mm)	4" (101.6mm)	5" (127.0mm)	6" (152.4mm)	7" (177.8mm)
		Grooved (3)	2 1/8" (58.7mm)	3 1/8" (84.1mm)	4 1/8" (109.5mm)	5 1/8" (134.9mm)	6 1/8" (160.3mm)
L		Threaded (2)	3 1/8" (79.4mm)	4 1/8" (104.8mm)	5 1/8" (130.2mm)	6 1/8" (155.6mm)	7 1/8" (180.9mm)
		Grooved (3)	2 1/2" (63.5mm)	3 1/2" (88.9mm)	4 1/2" (114.3mm)	5 1/2" (139.7mm)	6 1/2" (165.1mm)
M		Threaded (2)	3 3/8" (85.7mm)	4 3/8" (111.1mm)	5 3/8" (136.5mm)	6 3/8" (161.9mm)	7 3/8" (187.3mm)
		Grooved (3)	2 1/16" (68.3mm)	3 1/16" (93.7mm)	4 1/16" (119.0mm)	5 1/16" (144.5mm)	6 1/16" (169.9mm)
H		Threaded (2)	3 1/16" (93.7mm)	4 1/16" (119.0mm)	5 1/16" (144.5mm)	6 1/16" (169.9mm)	7 1/16" (195.3mm)
		Grooved (3)	3 3/8" (79.4mm)	4 3/8" (104.8mm)	5 3/8" (130.2mm)	6 3/8" (155.6mm)	7 3/8" (180.9mm)

NOTE: Always round up to the next full inch. Also, bent/frozen rods can be measured rod end to rod end to achieve the OAL.

4. Determine Overall Length (OAL)

Measure the cable, rod seal to rod seal (dimension "A", diagram 1). To arrive at the overall length, add the travel as determined in Step 4 and twice (2X) the thread length as shown in Chart 1 to dimension "A".

FORMULA OAL = "A" + Travel + 2X Thread Length

Example

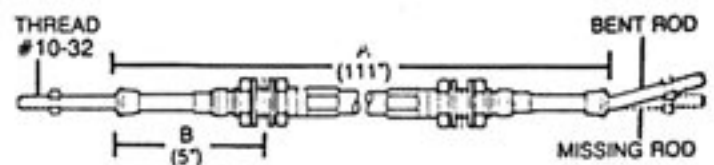

Standard Replacement PTO Control Cable

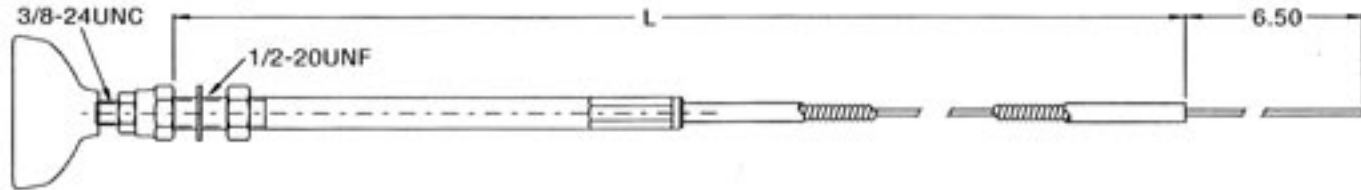

The quality replacement cable for power take-off control that equals or surpasses original equipment standards. Adaptable to mounting brackets of Muncie, Chelsea and similar cable-actuated PTOs.

Part No. 872-507-L
(Round Wire Construction)
("L" = Length)

PTO Cable Attachment Kit. (For use with non-lock cables)

Attach your custom-built cable to Chelsea or similar PTO units with the same mounting pattern that have a 3 inch hole-center to hole-center lever arm. Cable and handle ordered separately.

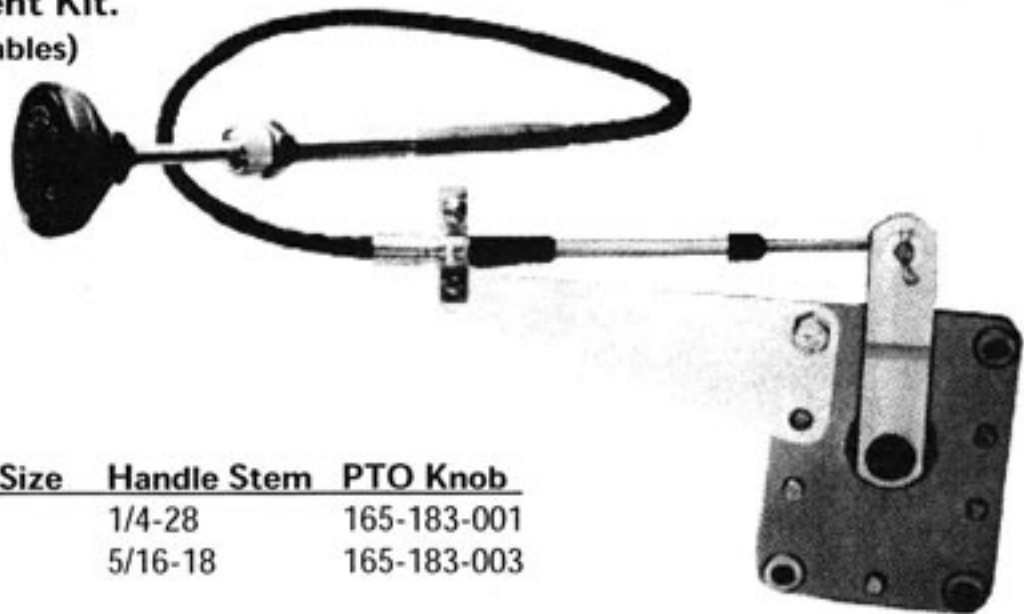

Attachment Kit	Cable Size	Handle Stem	PTO Knob
175-600-004	VLD	1/4-28	165-183-001
175-600-005	LD	5/16-18	165-183-003

Optional Knobs for Non-Lock Control Heads

Part numbers shown below are of reinforced black nylon. Specify knob in part number for all non-locking controls. (included in price)

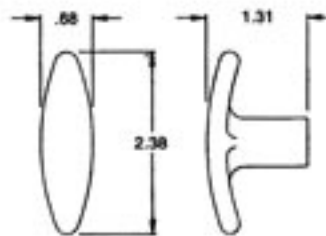

Inscription	Part Number		
	Thread Size		
	1/4-20	1/4-28	5/16-18
None	005	014	013
STOP	015	016	017
SHUTOFF	002	008	018
THROTTLE	019	020	021
CHOKE	022	023	024
OPEN	025	026	027
CLOSE	028	029	030
EMER. STOP	031	032	033
Inscription	Part Number		
	Thread Size		
	1/4-20	1/4-28	
None	306	308	
STOP	317	314	
SHUTOFF	318	319	
THROTTLE	320	321	
CHOKE	309	322	
OPEN	323	324	
CLOSE	325	326	
EMER. STOP	327	328	

Cast aluminum oversize T-handle
(not included in price)

Inscription	Part Number		
	Thread Size		
	1/4-20	1/4-28	5/16-18
None	201	202	203

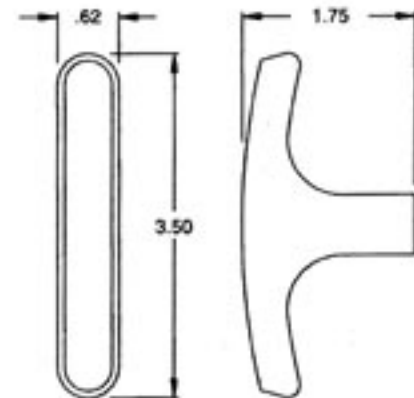

Locally Assembled Control Head Cables

Order Knob from Chart Below

KNOB THREAD DIAMETER	
Utility/Low-Friction EXT	
VLD	1/4-28 UNF
LD	5/16-18 UNC
Commercial	
VLD	1/4-20 UNC
MOUNTING HOLE DIAMETER	
Utility/Low-Friction EXT	
VLD	7/16 diam.
LD	5/8 diam.
Commercial	3/8 diam.



Thumb release for coarse setting and rotation for fine setting. Friction lock or dust cover available (below).



Utility & Low-Friction EXT

1", 2" and 3" travel
2" min. bend radius on VLD
3" min. bend radius on LD
60 lb. load rating

How to Order

1. Select the basic part number.
2. Indicate travel per example below.
3. Indicate length in inches.

Part Number Code Example:

56V32 - 3 - 120

Length in inches
1", 2" or 3" travel
Basic Part Number (example is Twist-Lock with threaded end fitting and stainless steel end rod).
V-Very Light Duty (VLD)
L-Light Duty (LD)

	NON-LOCKING		MICRO-ADJUST		TWIST-LOCK	
	VLD	LD	VLD	LD	VLD	LD
Utility	86V32*	96L32*	26V32*	26L32*	56V32*	56L32*
	86V42**	96L42**	26V42**	26L42**	56V42**	56L42**
Low-Friction EXT	81V32*	91L32*	21V32*	21L32*	51V32*	51L32*
	81V42**	91L42**	21V42**	21L42**	51V42**	51L42**
Utility	86V33*	96L33*	26V33*	26L33*	56V33*	56L33*
	86V43**	96L43**	26V43**	26L43**	56V43**	56L43**
Low-Friction EXT	81V33*	91L33*	21V33*	21L33*	51V33*	51L33*
	81V43**	91L43**	21V43**	21L43**	51V43**	51L43**
Commercial						
VLD Trim-to-length Control Head Cables with stainless steel wire innemember.	79V00		29V00		59V00	
	79V04		29V04		59V04	
Up to 3" travel 5" min. bend radius 20 lb. pull load rating.	79V05		29V05		59V05	

Output End Options

Threaded Conduit End Fitting

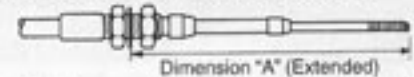

Travel	VLD	LD
1"	4.94	5.18
2"	6.93	7.18
3"	8.94	9.18

Grooved Conduit End Fitting

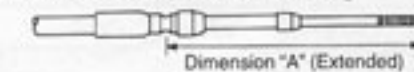

Travel	VLD	LD
1"	4.25	4.56
2"	6.25	6.56
3"	8.25	8.56

Twist-On Conduit Ends

- 3/8" diam.
No. 161-775-000
- 3/8-24 UNF
No. 161-581-000
- 3/8" diam.
No. 161-579-000

*3 = Stainless steel end rod **4 = Stainless steel end rod, support tube and innemember armor

Optional Knobs for Non-Locking Controls

	Utility and Low-Friction EXT		Commercial Trim-to-Length
	VLD	LD	
Thread Sizes	1/4 - 28 UNF	5/16 - 18 UNC	1/4 - 20 UNC
1" Round	165-172-308	None	165-172-306
2.4" T-Handle	165-172-014	165-172-013	165-172-005
2" Mushroom	165-103-001	165-103-006	165-103-002
2" PTO	165-183-001	165-183-003	165-183-002

Friction Lock

To order, add suffix "F" to Micro-Adjust part numbers. For example 16V02F would indicate a Friction Lock with a utility cable and a threaded conduit end fitting.

(Must be attached prior to assembly).



Commercial Control Heads

Factory assembled, trim-to-length, with stainless steel solid wire innermember.
Up to 3" travel, 5" min. bend radius and 20lb. pull load rating.

Micro Adjust

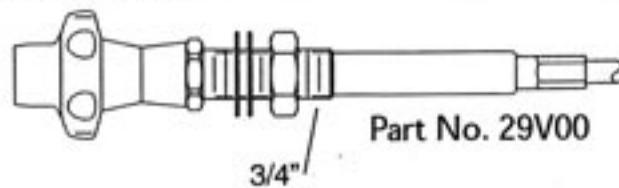

Twist Lock

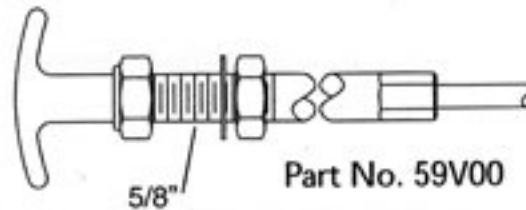

Non-Lock - (Shown with 306 Knob)

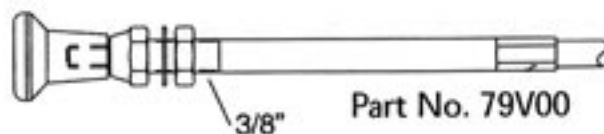

Twist-On Conduit Ends

(Standard for Control Heads on left)

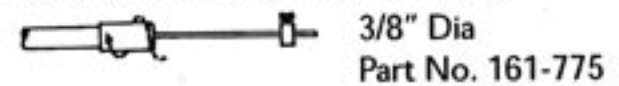

(Optional for Control Heads on left)

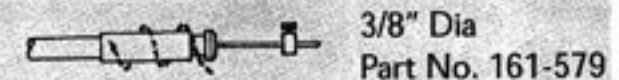
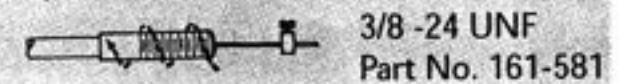

Friction-Lock Kit

For Part No. 29V00. Includes adjustment ring and compression washer.

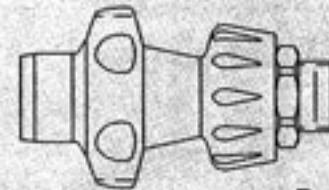

Truck Throttle Control

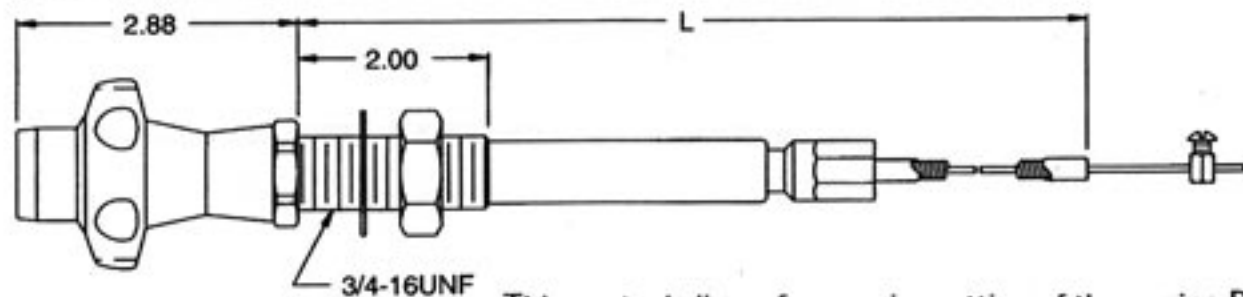

Part No. 286-009-L
("L" = Length)

This control allows for precise setting of the engine RPM when the PTO is engaged or as a manual control of the idle position during engine warm up. (Friction lock optional)

Non-Locking, Non-Rotating Control Head

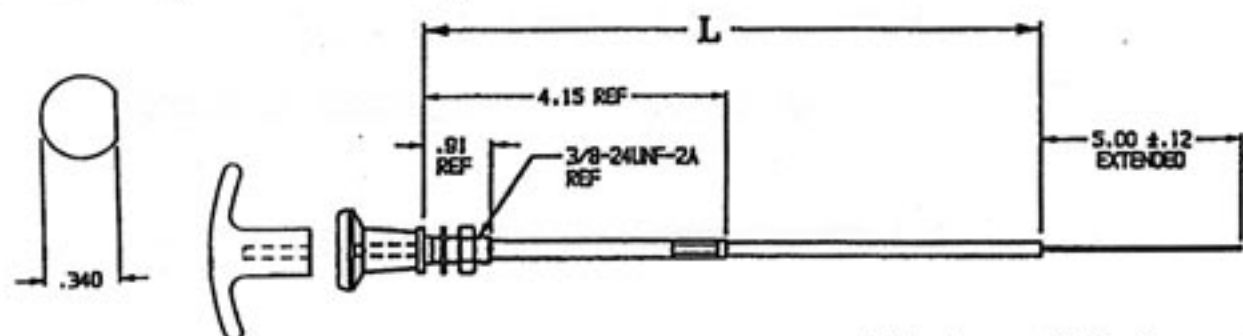

Part No. 165-438-L Black T-Handle ("L" = Length)
Part No. 165-437-L Black Knob ("L" = Length)

Spiral wound flat wire conduit
.054" solid stainless innermember

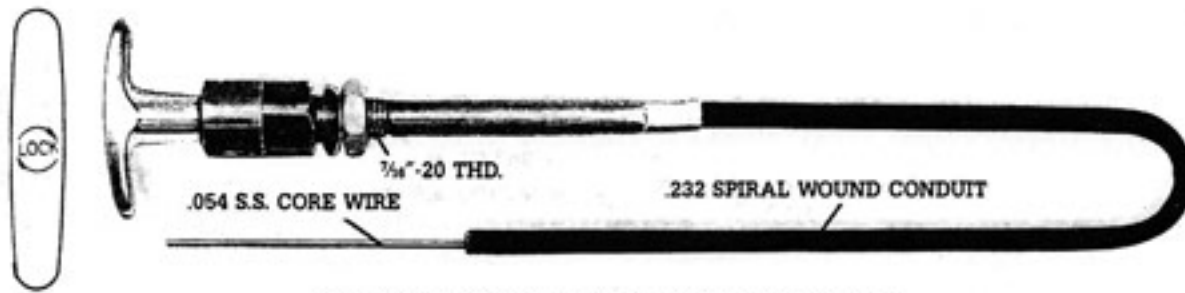

Spiral wound can be cut with side cutting pliers.

LIGHT DUTY TWIST LOCK

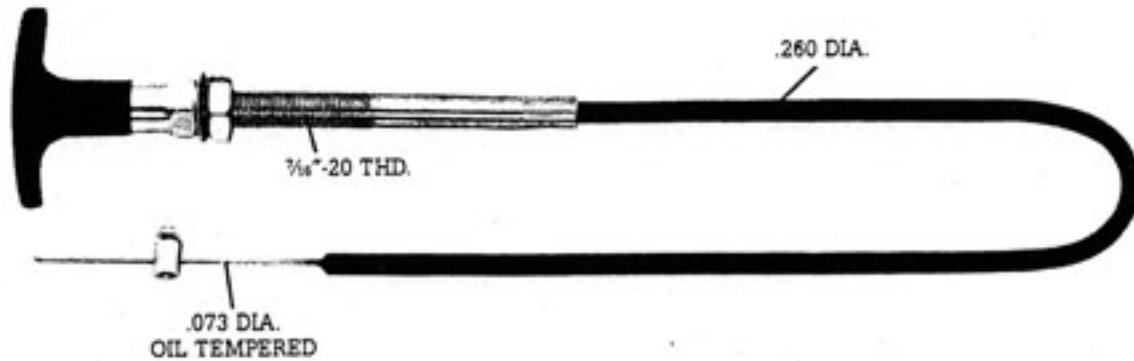

MEDIUM DUTY TWIST LOCK



LIGHT DUTY CHOKE CABLE

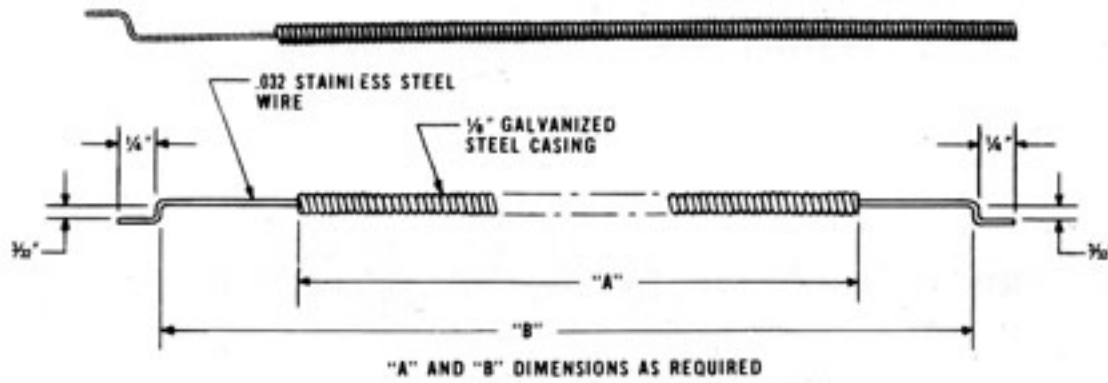

Light Load Connector Controls

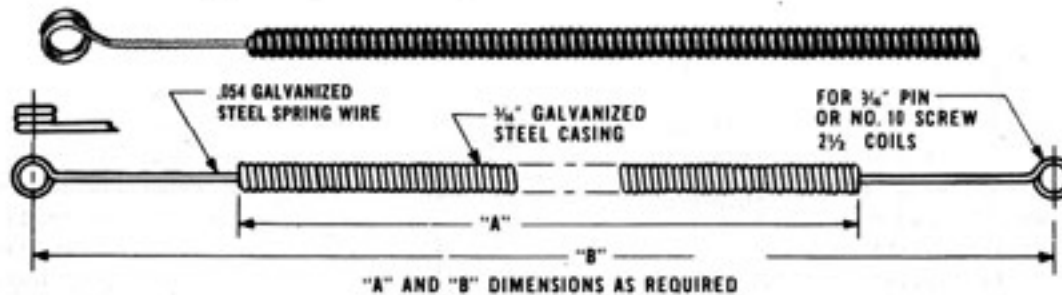

CUSTOM BUILT CABLES

SPECIALTY CABLES
A-Z
PUSH-PULL - BRAKE - CLUTCH

* IF IT'S A CABLE WE CAN BUILD IT *

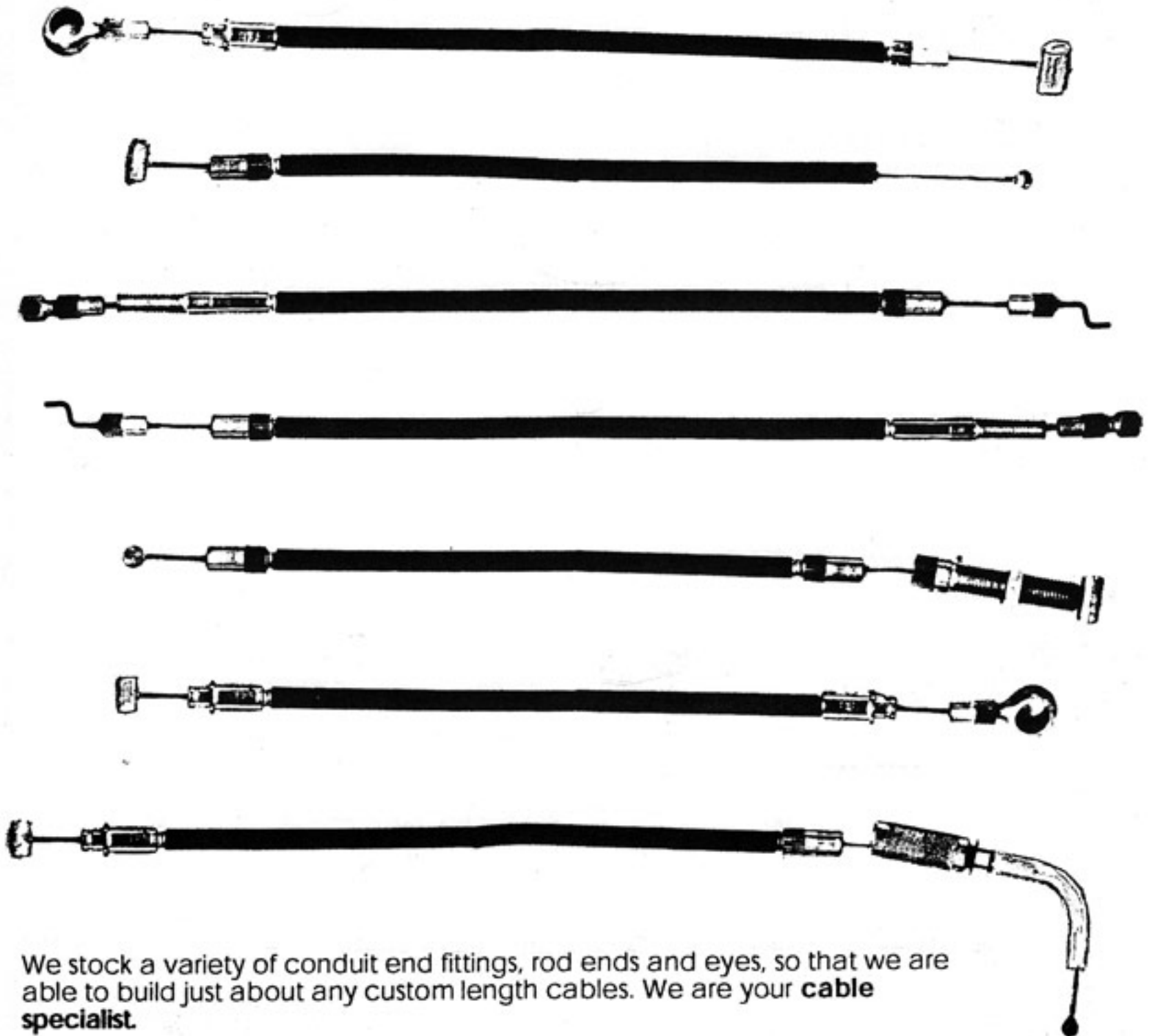

We stock a variety of conduit end fittings, rod ends and eyes, so that we are able to build just about any custom length cables. We are your **cable specialist**.

Automotive shift cables.

Replacements for popular brand shift cables.

Order Code: X=3 for Carbon Steel, X=4 for Stainless Steel; L=Length

B&M shift

Part No. CA248-X-L

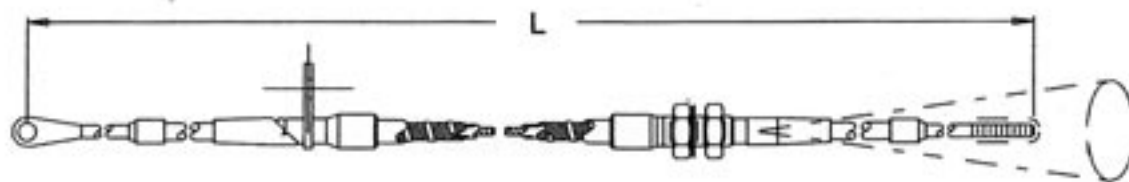

Dodge Motor Home

Part No. CA249-X-L

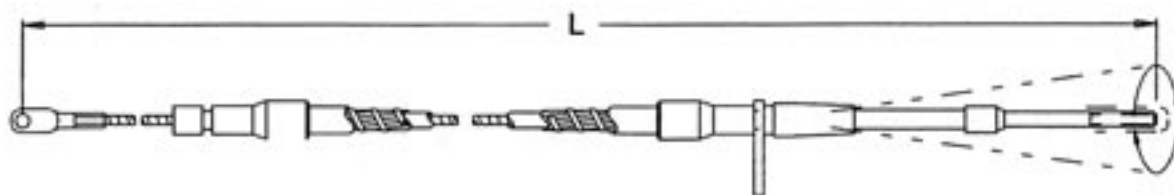

Hurst Shift

Part No. CA273-X-L

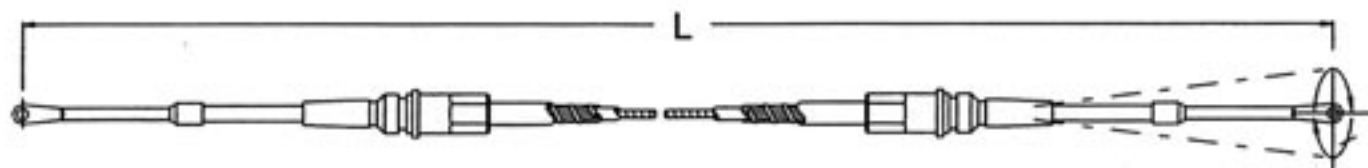

Hurst Shift

Part No. CA274-X-L

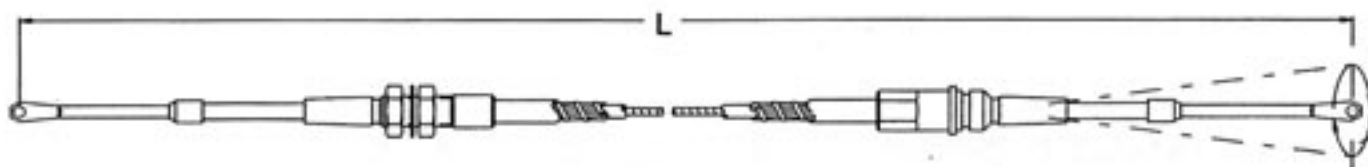

Hurst Shift

Part No. CA275-X-L

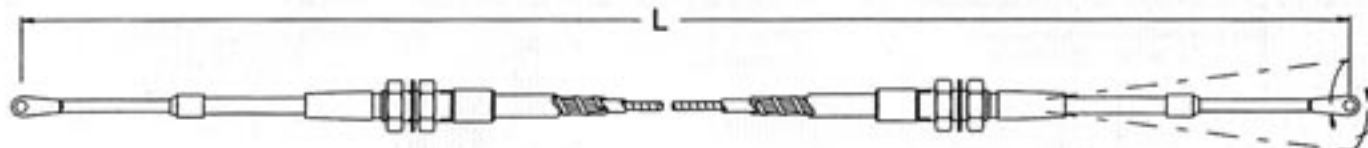

SPECIAL PURPOSE CONTROLS

PTO PUMP AND VALVE CONNECTION KITS

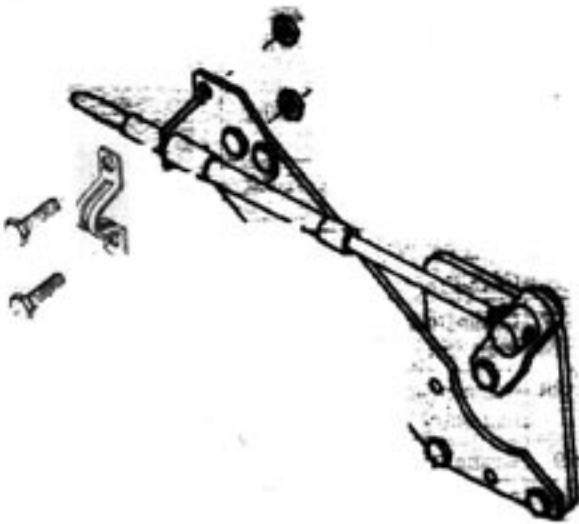

FOR DOUBLE GEAR CHELSEA AND
SIMILAR P.TO. PART NO BPT
FOR SINGLE GEAR PART NO BPTSG

BRISTOW ACCELERATOR PEDAL

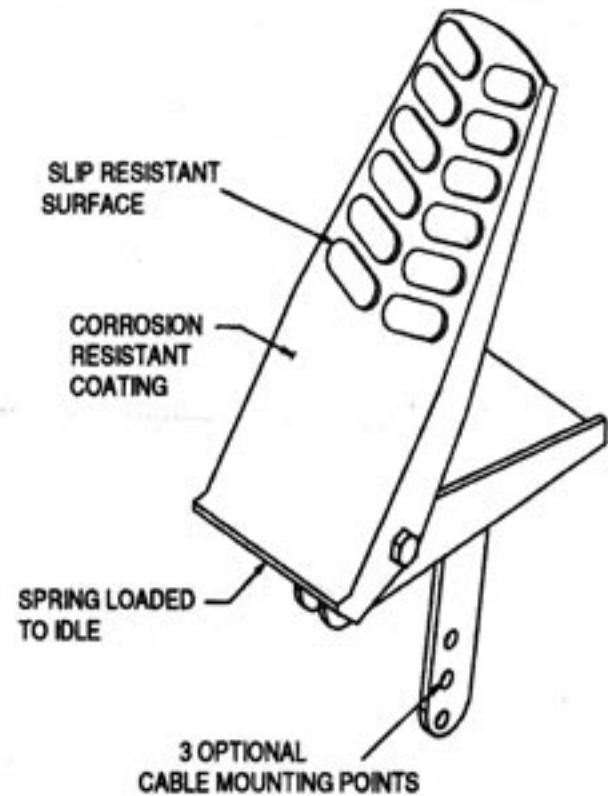

IDEAL FOR SMALL VEHICLES
LIGHT LOADS
WHEN ECONOMY IS IMPORTANT

VENT CONTROL

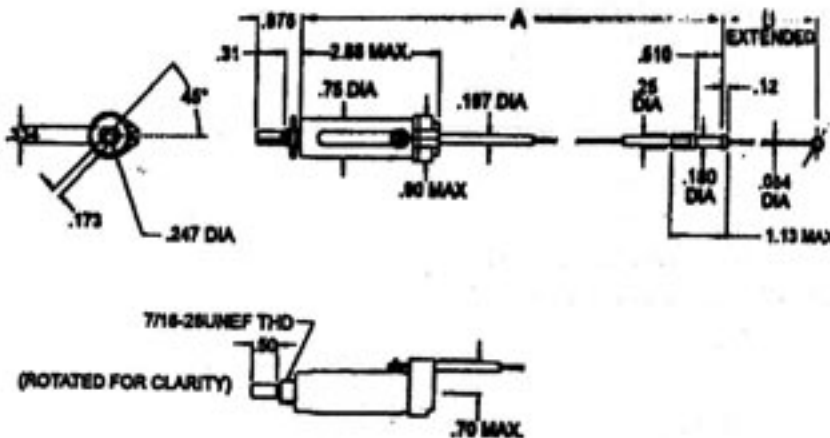

ROTARY TO LINEAR MOTION CONVERTER

Throttle/Accelerator Cables (Pull-Only)

Part No. A156-637-L (1/4-28 end rods) Grooved-Grooved
 Part No. A156-657-L (10-32 end rods) Grooved-Grooved

"A" dimension fixed in relation to "L" dimension.
 Bellows on both ends.



Part No. A156-638-L (1/4-28 end rods) Threaded-Grooved
 Part No. A156-658-L (10-32 end rods) Threaded-Grooved



Part No. A156-679-L (1/4-28 end rods) Threaded-Threaded
 Part No. A156-680-L (10-32 end rods) Threaded-Threaded



Part No. CA305-TT-A-L (1/4-28 end rods) Threaded-Threaded
 Part No. CA306-TT-A-L (10-32 end rods) Threaded-Threaded

"A" dimension variable in relation to "L" dimension.
 Bellows optional.

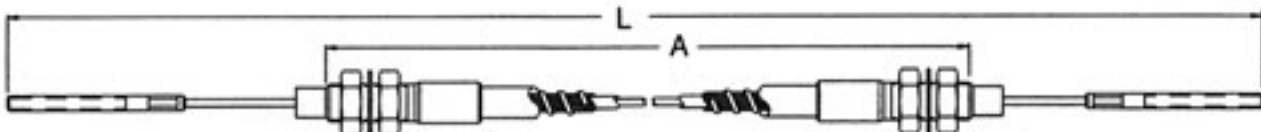

Part No. CA305-TG-A-L (1/4-28 end rods) Threaded-Grooved
 Part No. CA306-TG-A-L (10-32 end rods) Threaded-Grooved

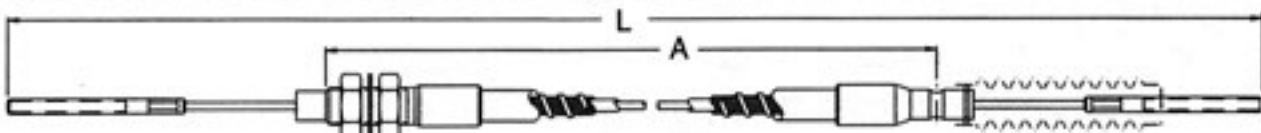

Part No. CA305-GG-A-L (1/4-28 end rods) Grooved-Grooved
 Part No. CA306-GG-A-L (10-32 end rods) Grooved-Grooved

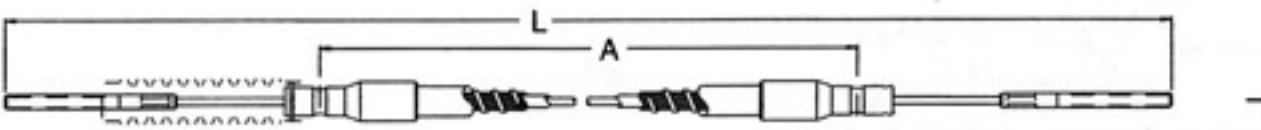

Part No. CA307-A-L (1/4-28 end rods) Special

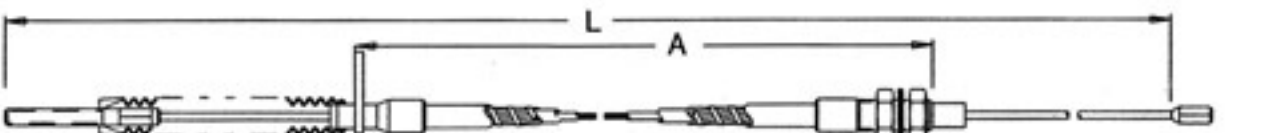

CLUTCH CONTROL CABLES

A High Quality
Replacement for Most
Cab Over Engine Vehicles.

The most flexible control cable in the industry.

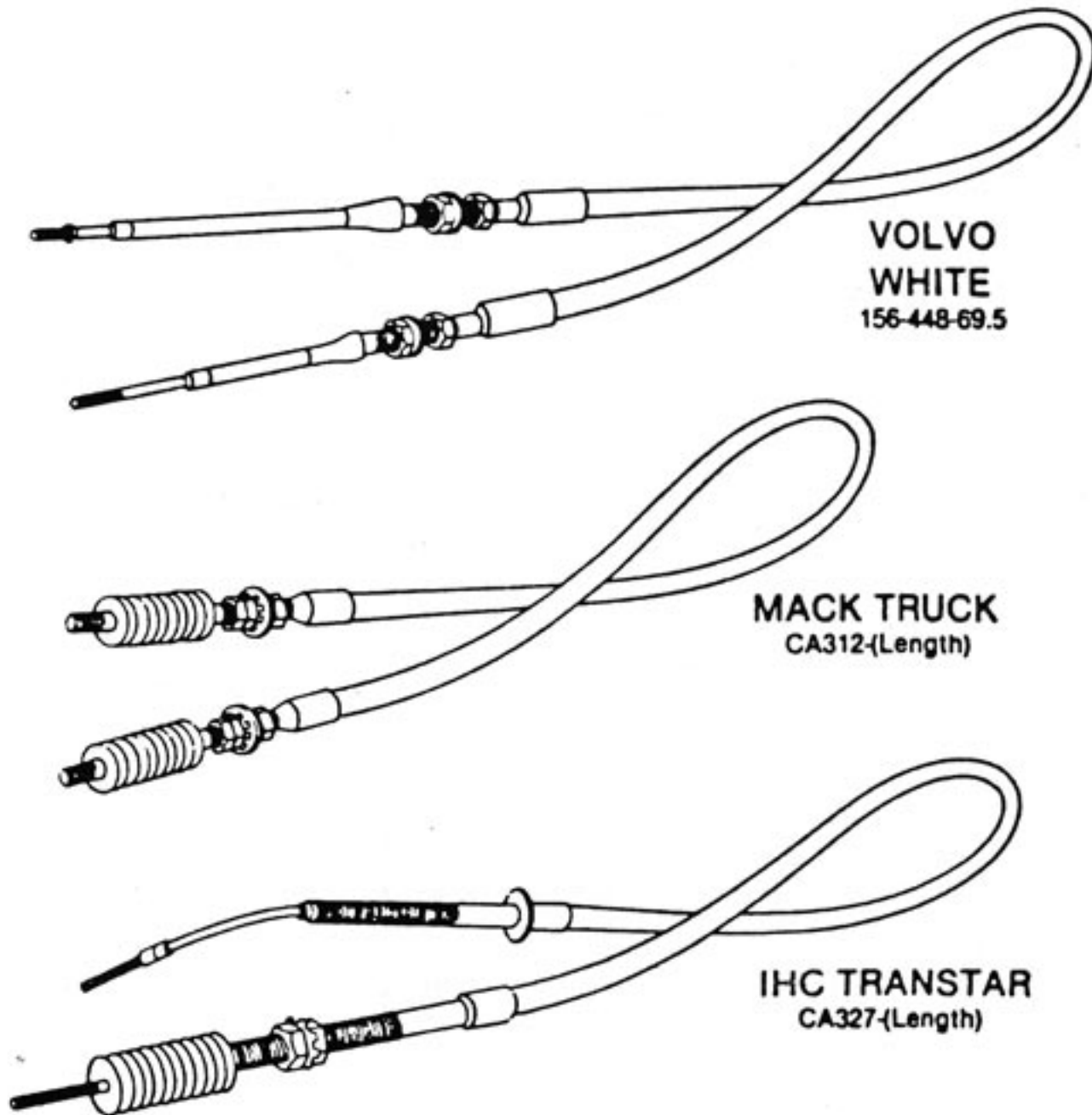

Smooth/Rugged & Reliable

All Cable Assemblers stock components for the immediate assembling of control cables to meet your requirements.

No other clutch cable offers the ease of installation that our added flexibility provides.

Order your cable by overall length or manufacturer's number.

Cable Assemblers will also provide same-day delivery on push-pull, PTO and brake cables.

Clutch Cables (Pull-Only)

High quality replacements for most cab-over engine vehicles and other similar applications. Built to your specifications by your local cable assembler.

Generic clutch replacement cables HD conduit, special clutch inner member.

Part No. CA235-A-L (5/16-24 end rods)

Part No. CA236-A-L (3/8-24 end rods)

Order Code: L=Length overall; A=Conduit length

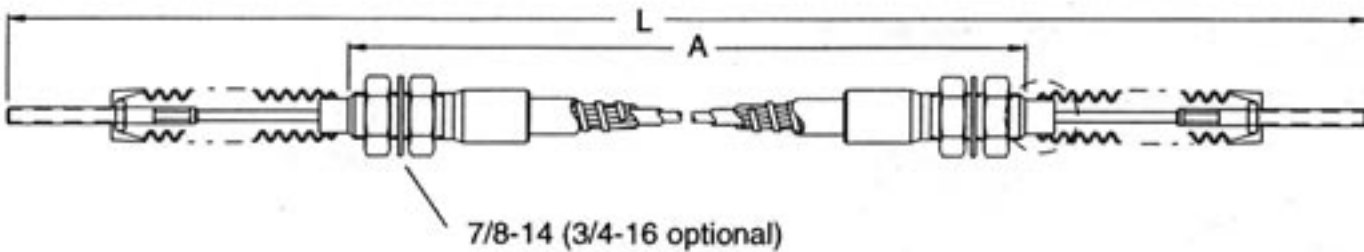

General Motors style clutch cable. 1500lb brake conduit and innermember.

Part No. CA270-XXX (XXX=Dash number, see table below)



Dash No.	Equivalent G/M Part No.	L	A	Conduit	Inner-member
-010	15520115	76.69	47.56	47.26	69.83
-009	15518380	71.65	43.31	43.01	64.79
-008	15518379	79.53	51.18	50.88	72.67
-007	15518378	74.21	44.88	44.38	67.35
-006	15518377	66.93	37.60	37.30	60.07
-005	15507983	69.01	44.55	44.25	62.15
-004	15507982	52.75	26.00	25.70	45.89
-003	15507981	72.91	45.27	44.97	66.05
-002	15507980	72.95	44.49	44.19	66.09
-001	15507979	68.07	40.94	40.64	61.21

General Motors style clutch cable. 1500lb brake conduit and innermember.

Part No. CA271-A-L (L=Length overall; A=Conduit length)

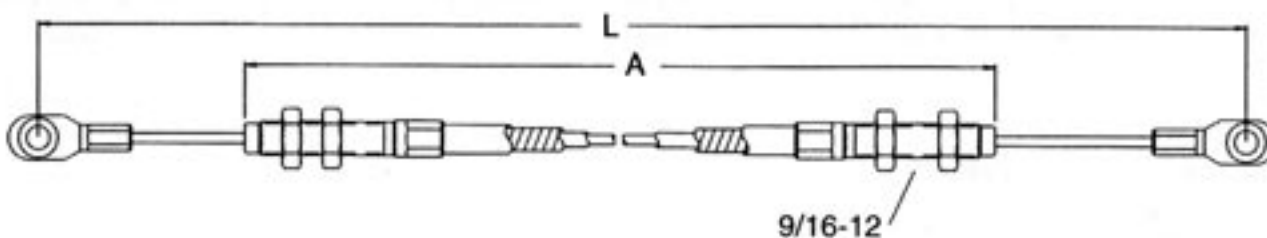

Clutch Cables (Pull-Only)

Mack Truck® style clutch cable. HD conduit and special clutch innermember.
Part No. CA312-A-L (A=Conduit length; L=Length overall; see table)

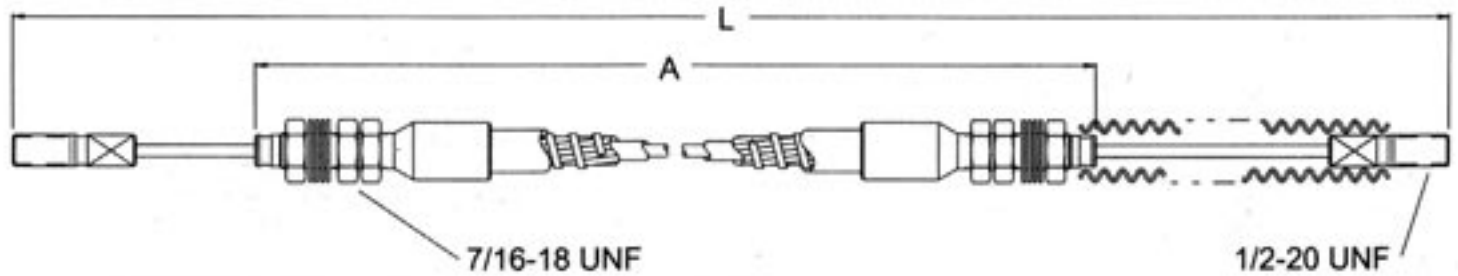

Part Number	A	L
CA312-34.6-42.0	34.6	42.0
CA312-55.6-63.0	55.6	63.0
CA312-79.6-87.0	79.6	87.0
CA312-85.6-93.0	85.6	93.0
CA312-91.6-99.0	91.6	99.0
CA312-102.6-110.0	102.6	110.0
CA312-127.6-135.0	127.6	135.0
CA312-25.6-36.0	25.6	36.0
CA312-34.6-45.0	34.6	45.0
CA312-43.6-54.0	43.6	54.0
CA312-55.6-66.0	55.5	66.0
CA312-67.6-78.0	67.6	78.0
CA312-79.6-90.0	79.6	90.0
CA312-85.6-95.0	85.6	96.0
CA312-91.6-102.0	91.6	102.0
CA312-103.6-114.0	103.6	114.0
CA312-118.6-129.0	118.6	129.0
CA312-29.6-40.0	29.6	40.0
CA312-95.6-106.0	95.6	106.0
CA312-107.6-188.0	107.6	118.0

IHC Transtar® style clutch cable. HD conduit and special clutch innermember.
Part No. CA327-L (L=Length overall)

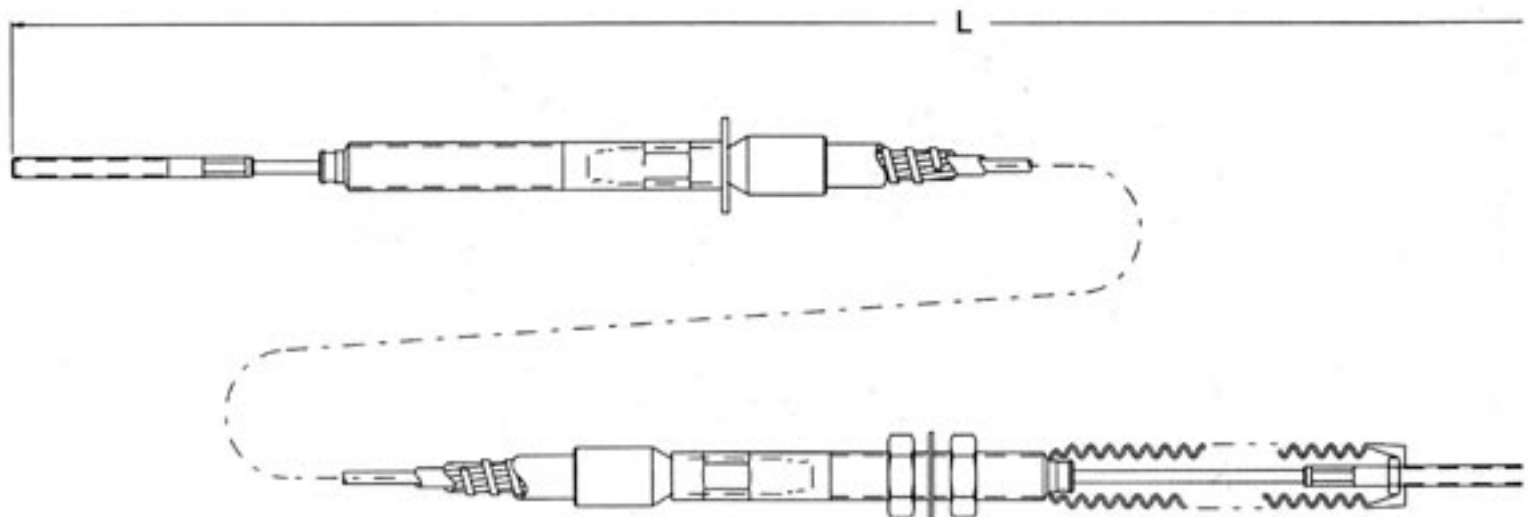

Cablecraft

CABLE AND CONTROL SYSTEMS

MIXER CABLE

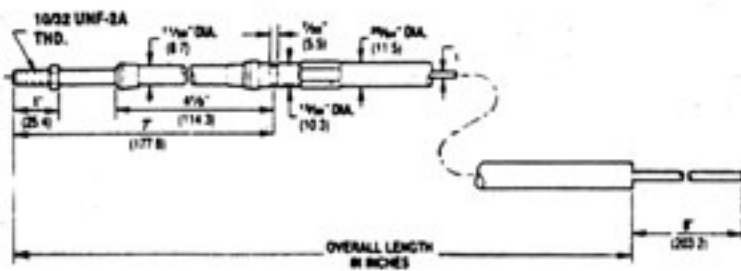

Part No. 173-571-G
3" TRAVEL

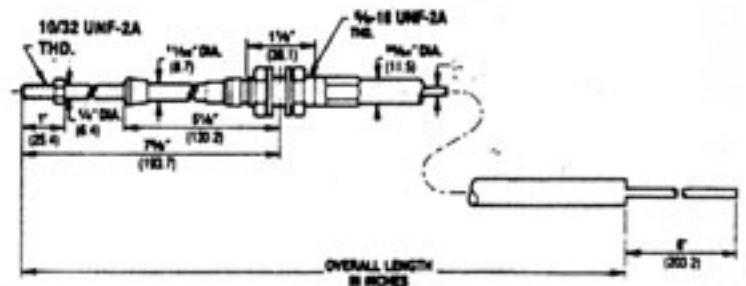

Part No. 173-571T
3" TRAVEL

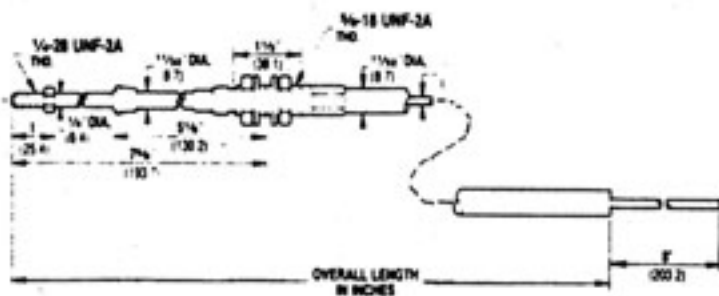

Part No. 173-371
3" TRAVEL

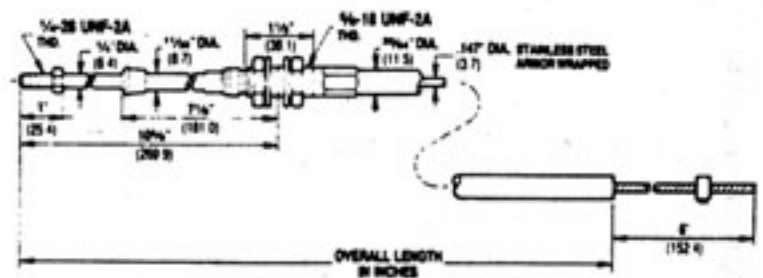

Part No. 173-371
5" TRAVEL

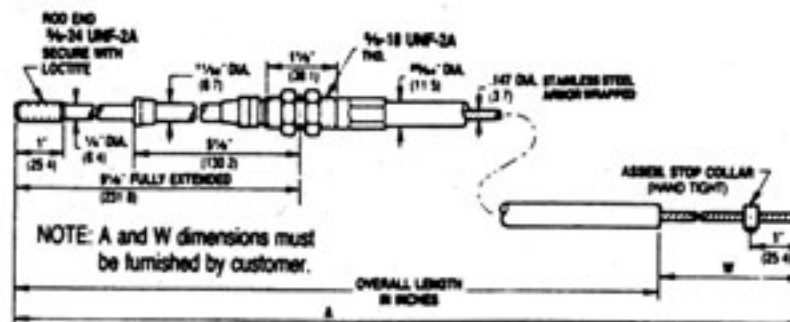

Part No. 173-371-006
3" TRAVEL

Remote Valve Control (RCV) Cables

Used to operate hydraulic valves. Ideal for wet-line kits, relocating valves, or vehicle modifications. Mounting kits available for most popular "spool" type valves.

Part No. A17X-334 Utility
Part No. A31X-334 EXT

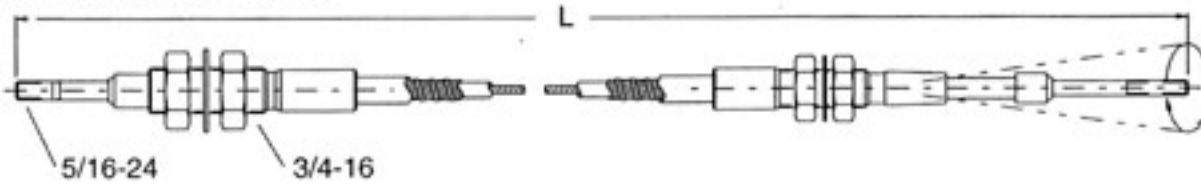

Part No. A17X-335 Utility
Part No. A31X-335 EXT

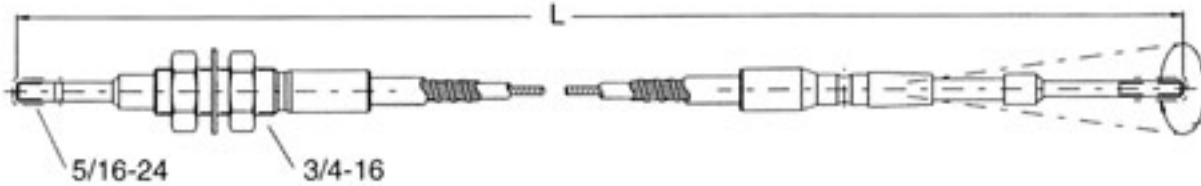

Part No. A17X-342 Utility



Part No. A17X-351 Utility

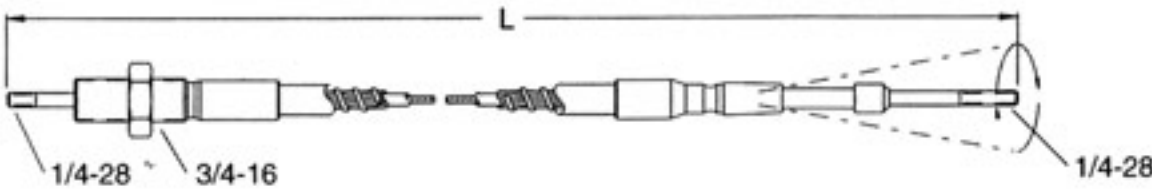

Part No. A17X-352 Utility

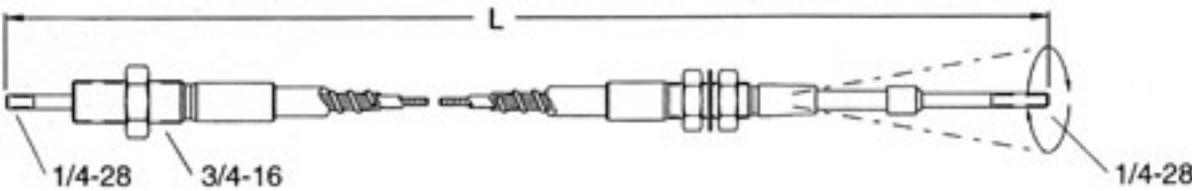

Remote Valve Control (RVC) Cables (continued)

Part No. CA260 Utility
Part No. CA261 EXT



Part No. CA22XG



Part No. CA22XT



Cable Mounting Kits

Cablecraft mounting kits fit most popular valves.

Part Number	For Use On:
185-101-001	Comm. Shearing 505
185-101-002	Comm. Shearing D50
185-101-003	Comm. Shearing A35
185-101-004	Comm. Shearing A20
185-101-005	Comm. Shearing VA20
185-101-006	HUSCO 6000
185-101-007	HUSCO 7120
185-101-008	Gresen V20, V31P, V42, CP, CT, CPT, CS, 25P, 5PK



Kit Includes:
Adapter Bracket, Clevis,
Clevis pin, and hardware

CONTROL SYSTEMS

REMOTE VALVE CONTROL SYSTEM

Single Axis Remote Valve Control

Weatherproof zinc diecast control can be mounted on interior or exterior of vehicle. Units can be mounted singly or stacked for multi-spool valves.

PART NO.	DESCRIPTION	WEIGHT
B206301	Single axis remote valve control	2.95 lbs.

All dimensions shown are nominal.

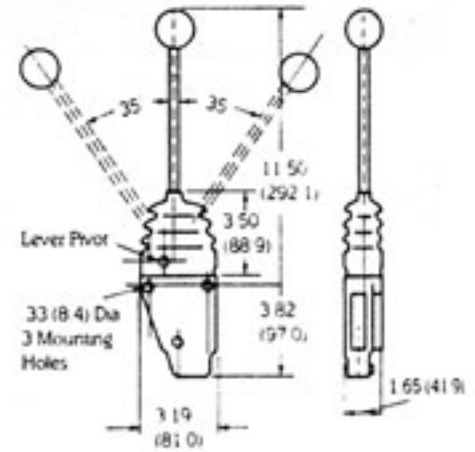

Single Axis with Detent Remote Valve Control

Like single axis model with added safety feature of detents.

PART NO.	DESCRIPTION
B206301001	Single axis remote valve control w/center detent
B206301002	Single axis remote valve control w/end detent
B206301003	Single axis remote valve control w/center and end detent

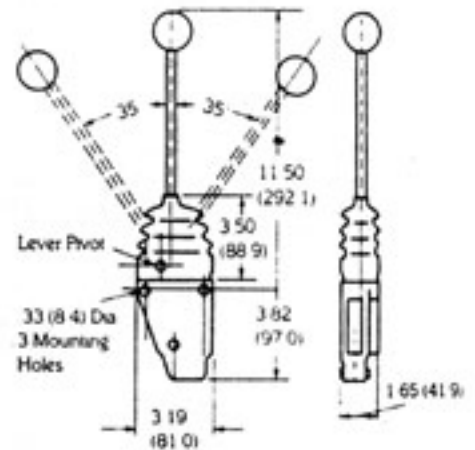

Dual Axis Remote Valve Control

Dual axis controls are used to control two valves simultaneously.

PART NO.	DESCRIPTION
B206305	Dual axis remote valve control

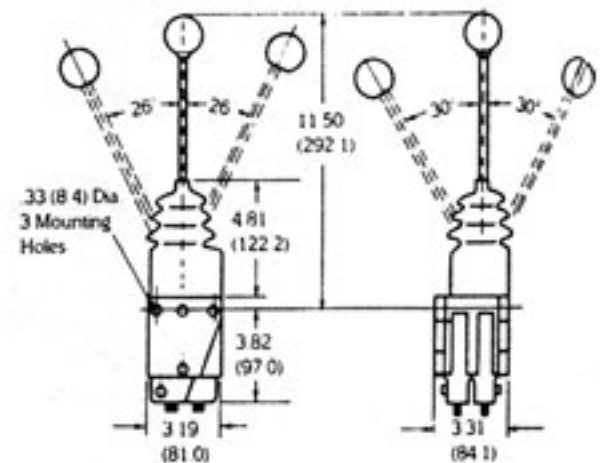

QUADCO® VALVE ADAPTER KITS

for
CABLE OPERATED, DIRECTIONAL CONTROL SPOOL VALVES

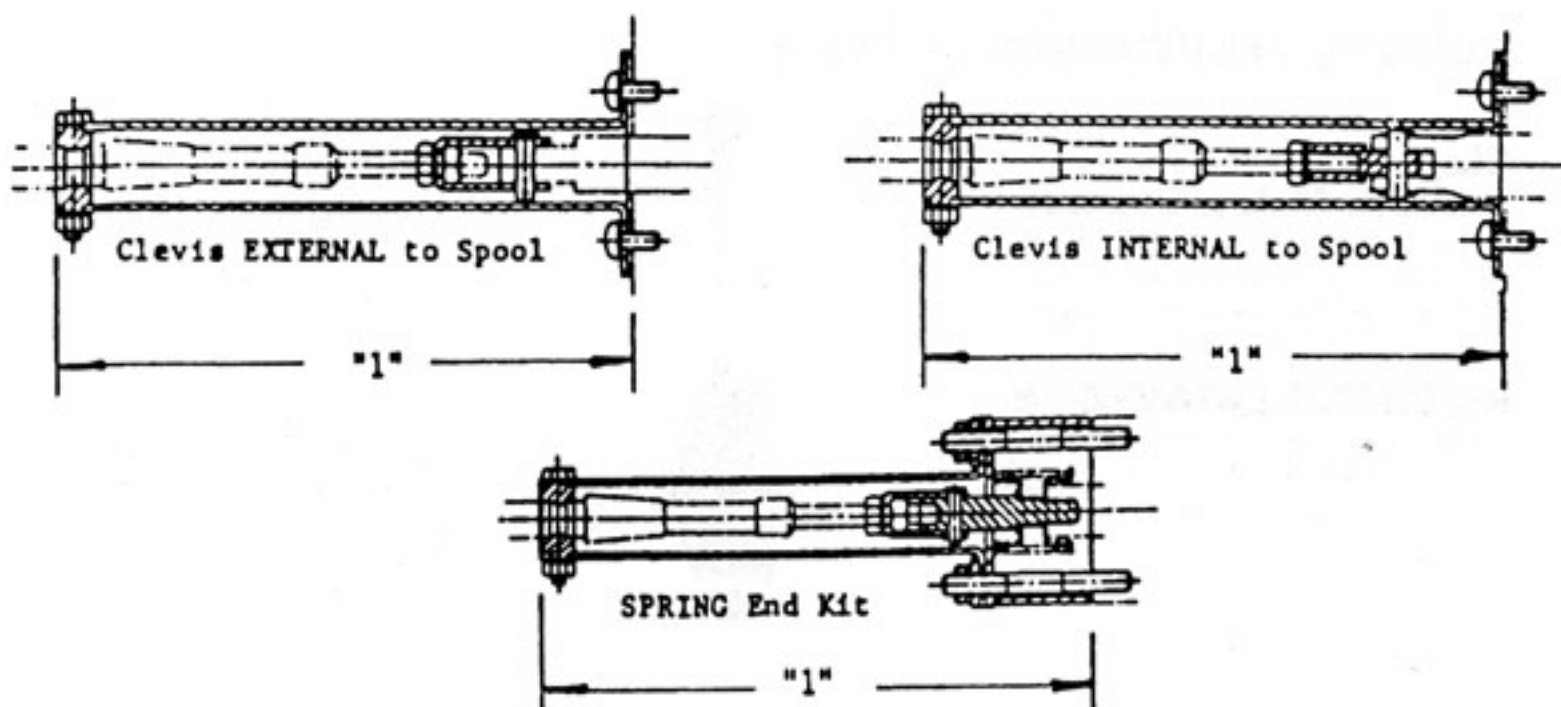

VALVE ADAPTOR KIT PART NUMBERS

MAKE	MODEL	QUADCO PART NUMBER		CLEVIS STYLE	LENGTH "1"	
		CABLE SIZE 1/4-28	CABLE SIZE 5/16-24		C4 KIT	C6 KIT
BRAND	** T52755	C455	--	External	8.22	----
CESSNA	33100	C415	C615	External	8.05	8.40
	33200	C416	C616	External	8.05	8.40
	33300	C417	C617	External	8.05	8.40
	33400	C418	C618	External	8.40	8.40
	33700	C415	C615	External	8.05	8.40
COMMERCIAL	A20	C410	C610	Spring End	8.90	8.90
	VA20	C432	C632	External	7.70	8.05
	A35	C419	C619	Spring End	9.00	9.00
	*505/506/507	C425	C625	Internal	8.05	8.40
CROSS	3CV/PC	C403	C603	External	7.70	8.05
	3LR/LS	C403	C603	External	7.70	8.05
	BA	C402	C602	External	7.70	8.05
	BC	C402	C602	External	7.70	8.05
	CA	C402	C602	External	7.70	8.05
	CD	C402	C602	External	7.70	8.05
ENERGY	CVA200	C404	C604	Internal	8.05	8.40
	CVP	C405	C605	Internal	8.05	8.40
	CVSD	C404	C604	Internal	8.05	8.40
GRESEN	25P	C420	C620	Internal	7.70	8.05
	CS	C406	C606	Internal	8.05	8.40
	V12	C411	C611	External	7.70	8.05
	V20	C406	C606	Internal	8.05	8.40
	V20	C423	C623	Spring End	8.79	8.79
	V42	C407	C607	Internal	8.05	8.05
	V42	C424	C624	Spring End	9.00	9.00
HUSCO	** 3200/4200	C421	C621	Internal	9.00	9.00
	6000	C408	C608	External	7.70	8.05
PARKER	VDP11/12	C409	C609	External	7.00	7.35
PRINCE	RD5200/5300	C422	C622	External	7.97	8.32
RACINE	ML-15 (M)	C411	C611	External	7.70	8.05
	ML-15 (F)	C412	C612	Internal	7.70	8.05
	ML-25 (M)	C413	C613	External	7.70	8.05
	ML-25 (F)	C414	C614	Internal	7.70	8.05
REXROTH	MP-18	C429	C629	External	7.70	8.05

* One Kit is required for each Valve Section. i.e. 507 requires 3 Kits.

** This is a Two Section Valve and the Kit consists of two Cable Housings and an Adaptor Block.

WIRE ROPE ASSEMBLIES

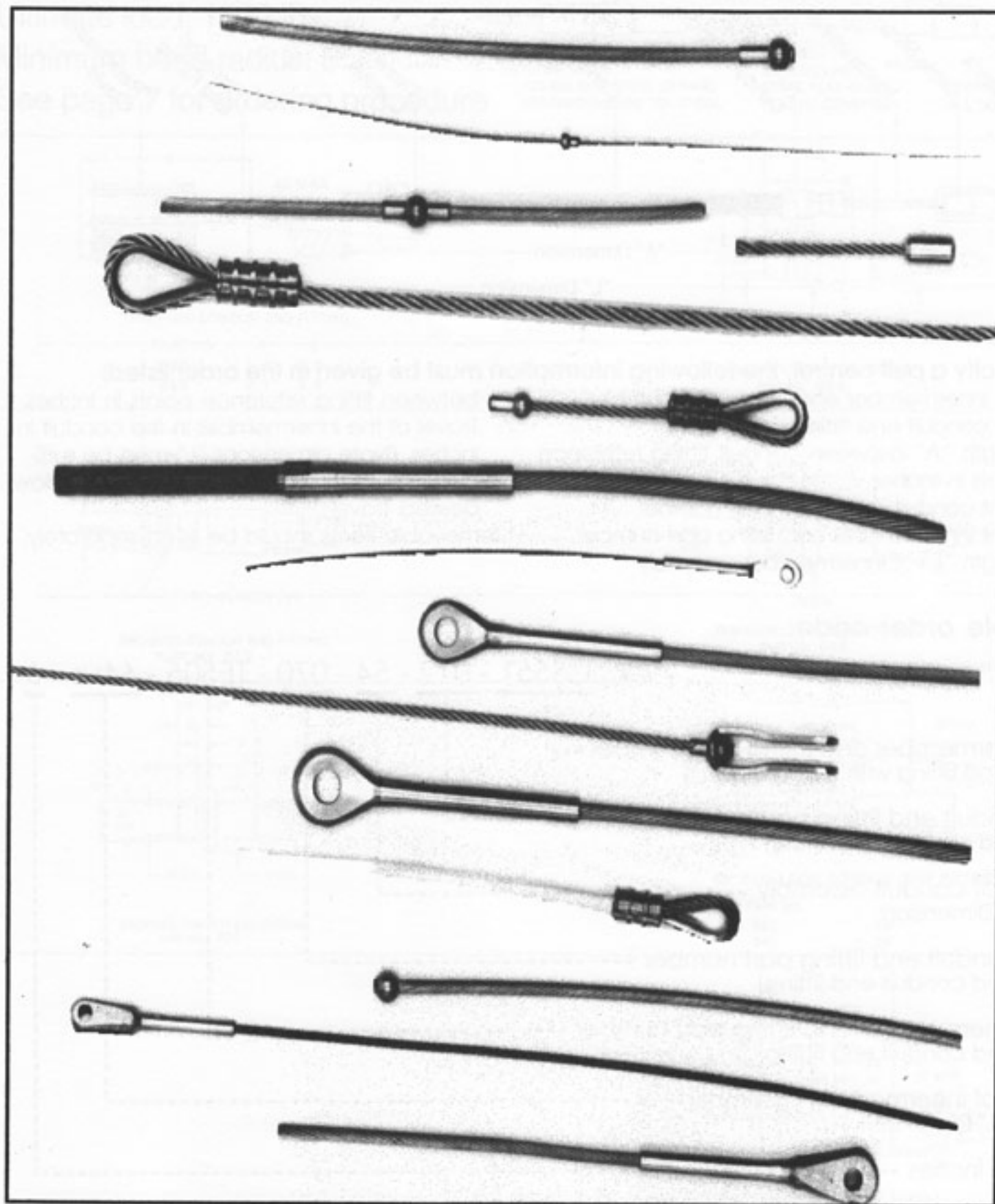

A WIDE VARIETY OF CABLE ASSEMBLIES ARE AVAILABLE USING STANDARD OR CUSTOM MACHINED FITTINGS, AND CABLE SIZES FROM 1/16 THRU 3/8 DIAMETER.

Preliminary Ordering Procedure

For pull-only cable controls

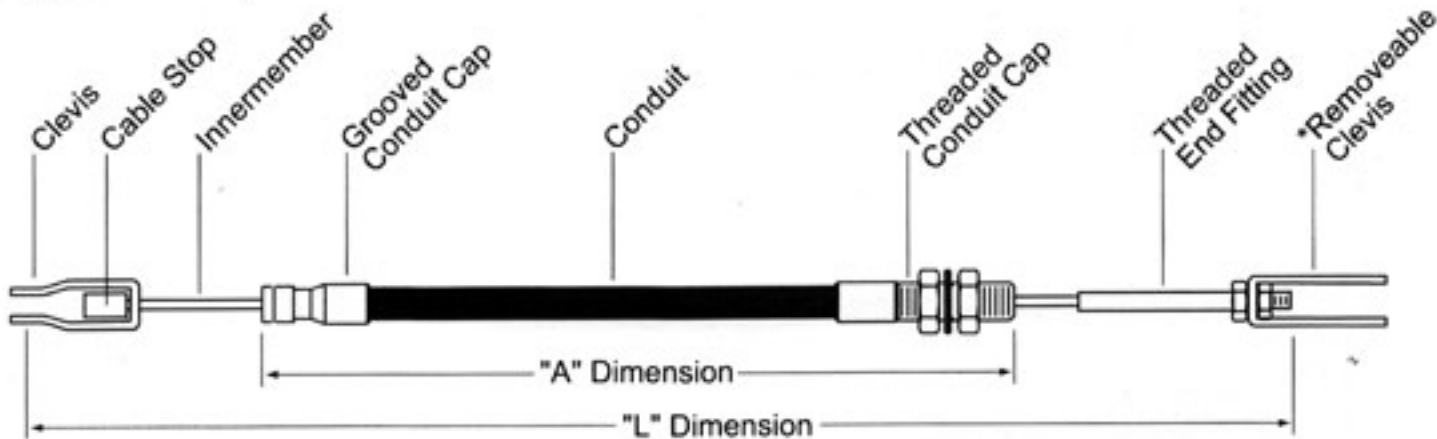

To specify a pull control, the following information must be given in the order listed:

1. Left innermember end fitting part number.
 2. Left conduit end fitting part number.
 3. Length "A" between conduit fitting reference points in inches.
 4. Right conduit end fitting part number.
 5. Right innermember end fitting part number.
 6. Length "L" of innermember assembly between fitting reference points in inches.
 7. Travel of the innermember in the conduit in inches. (Note dimensions "L" must be sufficiently greater than dimension "A" to allow desired travel).
- *Removable items should be listed separately.

Sample order code:

CS551 - 072 - 54 - 070 - TE505 - 64¹/₂ - 6

Left innermember end fitting part number ---
(Clevis end fitting with cable stop)

Left conduit end fitting part number ---
(Grooved conduit end fitting)

Length of conduit assembly ---
(54") "A" Dimension

Right conduit end fitting part number ---
(Threaded conduit end fitting)

Right innermember end fitting part number ---
(Threaded conduit end fitting)

Length of innermember assembly ---
(64¹/₂") "L" Dimension

Travel in inches ---
(6")

1500 POUND SERIES with Lined Conduit

- Ultimate load: 1500 lbs.
- Minimum bend radius: 5"
- See page 7 for ordering procedure

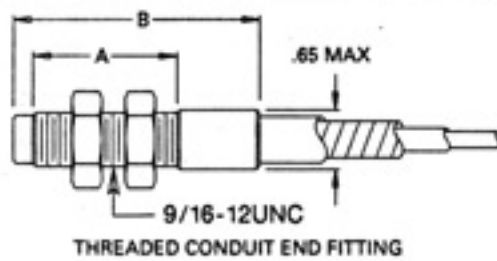
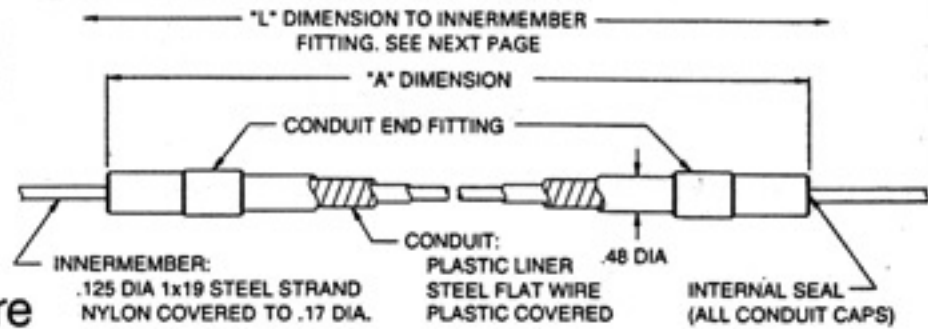

PART NO.	A	B
060	1.4	2.7
061	2.1	3.4

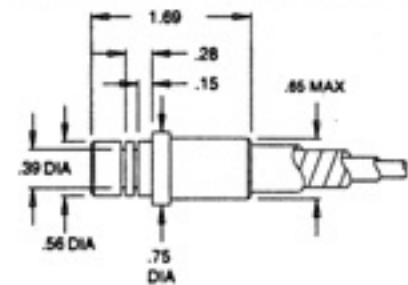

GROOVED CONDUIT END FITTING
PART NO. 064

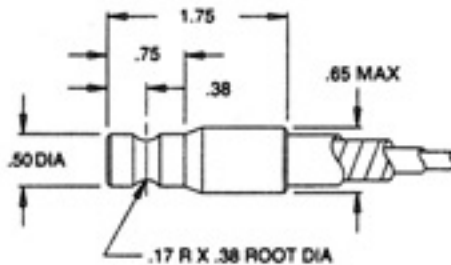

GROOVED CONDUIT END FITTING
PART NO. 062

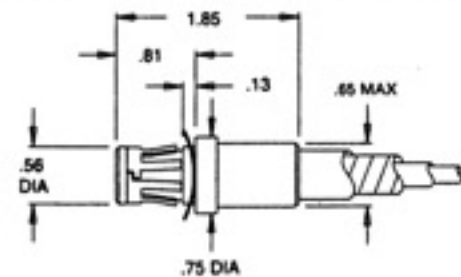

CLIP-LOCK CONDUIT END FITTING
PART NO. 065
For .125 and .187 thick material.

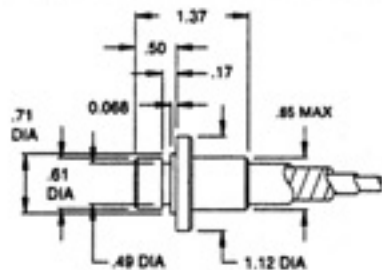

GROOVED CONDUIT END FITTING
PART NO. 026

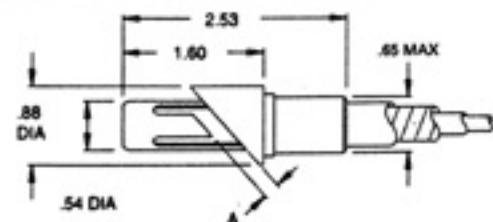

48° CLIP-LOCK CONDUIT END FITTING

PART NO.	A
066	.13
067	.20

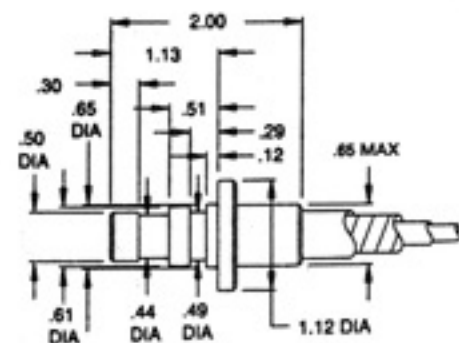

GROOVED CONDUIT END FITTING
PART NO. 027

CONDUIT END FITTINGS

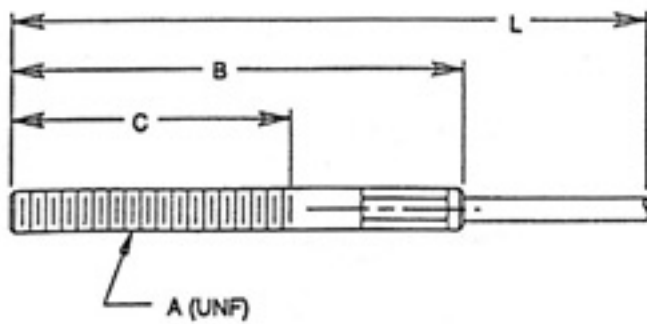

THREADED END FITTING

PART NO.	A	B	C
TE 504	5/16 -24	3.62	2.25
TE 504-6	5/16 -24	2.00	1.00
TE 506	3/8 -24	2.62	1.50
TE 523-001	1/4 -28	3.62	2.50

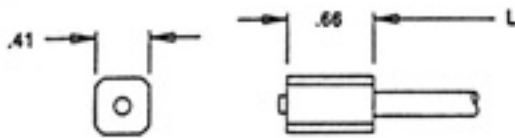

CABLE STOP
PART NO. BE 501

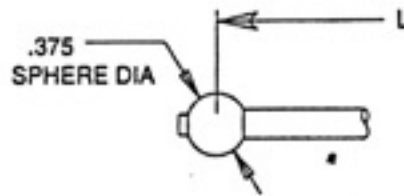

BALL END
PART NO. BT 821
(MAX-LOAD 2,000 lbs.)

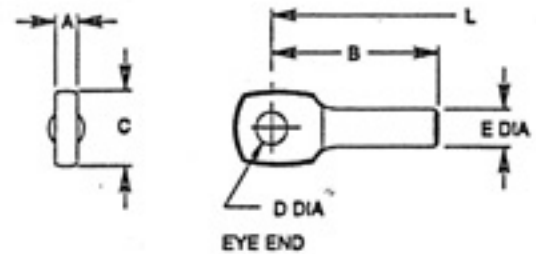

PART NO.	A	B	C	D	E
117-047-000	.235	1.81	.75	.323	.375
EE 9158	.240	1.60	.75	.500	.437

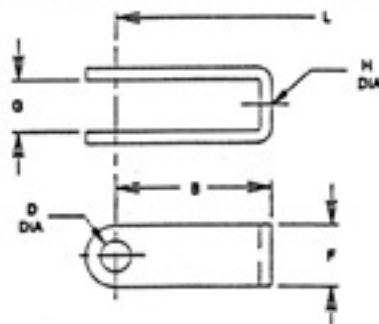

OPEN STRAP CLEVIS

PART NO.	B	D	F	G	H
CS 540	1.62	.31	.62	.43	.266
CS 540-1	1.62	.31	.62	.51	.266
CS 540-6	2.50	.38	.75	.57	.386
CS 540-7	2.50	.31	.62	.51	.266
CS 541	1.94	.38	.75	.51	.266
CS 541-3	1.94	.38	.75	.51	.323
CS 541-5	2.00	.38	.75	.51	.266
CS 541-7	2.50	.38	.75	.51	.266
CS 541-8	2.50	.38	.75	.51	.323
CS 542	1.08	.50	1.00	.58	.323

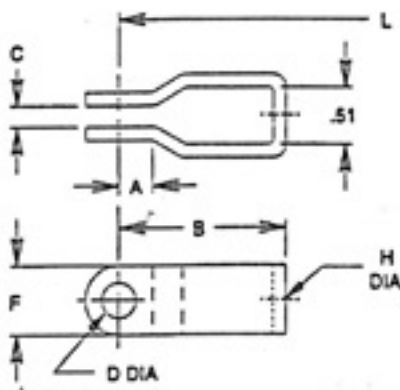

STEP STRAP CLEVIS

PART NO.	A	B	C	D	F	H
CS 550	.31	1.56	.19	.31	.62	.266
CS 550-1	.31	1.56	.19	.38	.62	.266
CS 550-2	.31	1.56	.19	.31	.62	.316
CS 550-4	.31	1.56	.19	.25	.62	.266
CS 551	.38	1.75	.25	.31	.62	.266
CS 551-1	.38	1.75	.25	.38	.62	.266
CS 551-2	.75	2.38	.25	.31	.62	.316
CS 551-3	.38	1.50	.25	.25	.62	.266
CS 552	.31	2.38	.25	.31	.75	.266
CS 552-1	.31	2.38	.25	.38	.75	.266
CS 552-3	.38	2.38	.25	.43	.75	.316
CS 552-4	.38	2.38	.25	.31	.75	.316
CS 553	.50	1.88	.19	.38	.75	.266

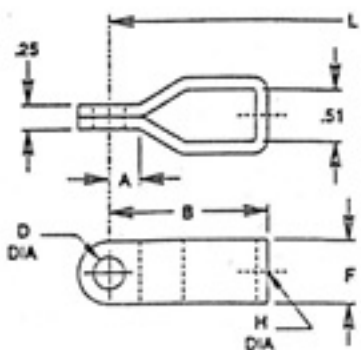

CLOSED STRAP CLEVIS

PART NO.	A	B	D	F	H
CS 562	.31	1.62	.31	.62	.316
CS 562-2	.31	1.62	.19	.62	.316
CS 563	.28	1.75	.31	.62	.316
CS 564	1.00	2.38	.38	.75	.316

INNERMEMBER END FITTINGS

STRAP CLEVIS PART NUMBERS
APPLY TO BOTH 1500
AND 3000 SERIES.

3000 Pound Series with Lined Conduit

Ultimate load: 3000 lbs.
 Minimum bend radius: 7"
 See page 11 for ordering procedure.

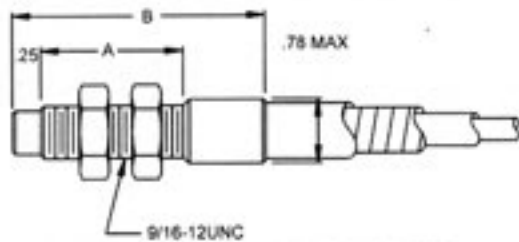
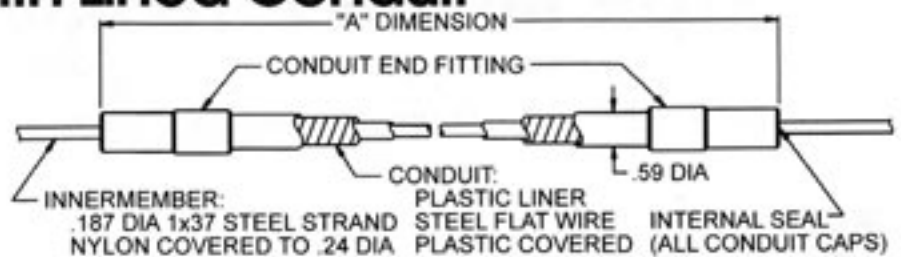

Threaded Conduit End Fitting

Part No.	A	B
070	1.4	2.7
071	2.0	3.3

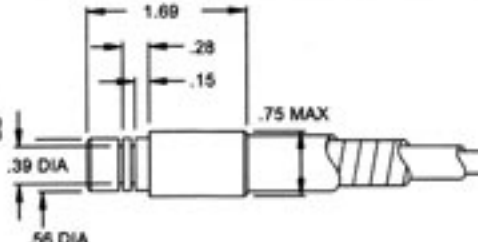

Grooved Conduit End Fitting

Part No.	Use E-Clip
074	175-435-025

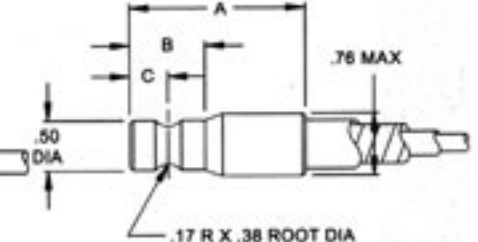

Grooved Conduit End Fitting

Part No.	A	B	C
072	1.4	2.7	.38
073	2.0	3.3	.44

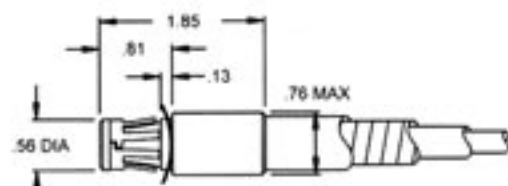

Clip-Lock Conduit End Fitting

Part No.
075

For .125 or .187 thick material.

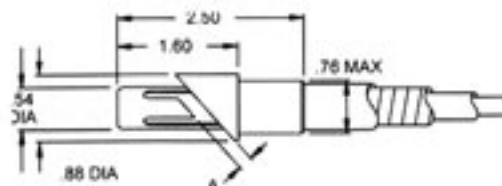

48° Clip-Lock Conduit End Fitting

Part No.	A
076	.33
077	.20

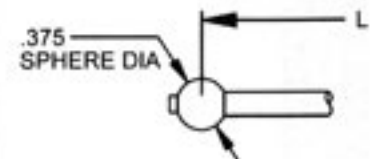

Ball End

Part No. BT 822
 (Max-load 2,000 lbs.)

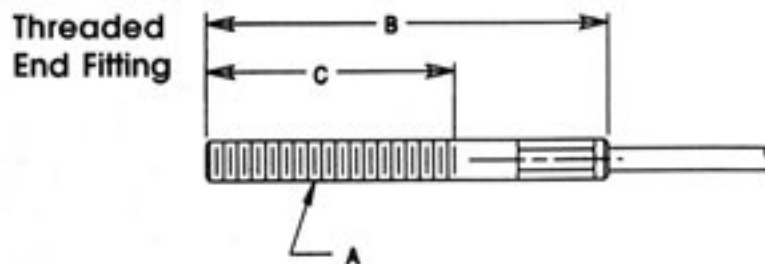

Part No.	A	Swaged	C
TE 505	3/8-24	2.95	2.00
TE 505-1	3/8-24	1.88	1.00
TE 508	3/8-24	2.62	1.50
TE 509-1	3/8-24	4.95	3.75
TE 510-1	5/16-24	2.50	1.50
TE 510-2	5/16-24	3.62	2.24
TE 510-4	5/16-24	4.00	3.00
TE 510-5	1/4-28	3.62	2.50
TE 510-6	5/16-24	2.12	1.00
TE 510-7	5/16-24	2.88	1.50
TE 510-8	5/16-24	5.60	4.47
TE 510-9	5/16-24	3.00	1.91
TE 605	3/8-24	6.00	5.00



Cable Stop

Part No. BE 502

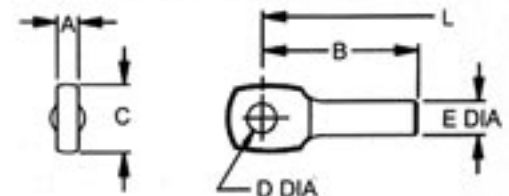

Eye End

Part No.	A	B	C	D	E
157-047-002	.235	1.81	.75	.323	.375

See page 28 for strap clevis part numbers.

MOUNTING CONFIGURATIONS

SIDE MOUNT 165-508-008

2.5 inches (64mm) wide SIDE PLATES; ONE CABLE, with three alternate sets of cable clamp holes. For cowl, instrument panel, seat riser, or frame installation.

Side Mount 165-508-008

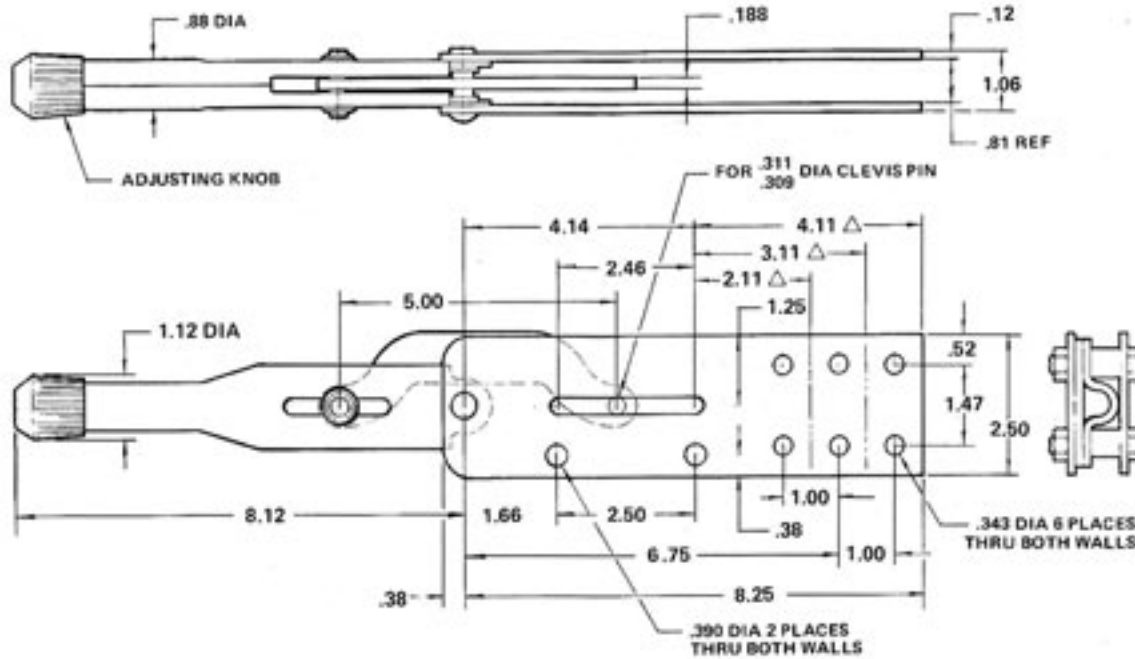

SUPPLIED WITH THE FOLLOWING HARDWARE:

- CLEVIS PIN
- COTTER PIN
- WASHER
- MOUNTING SPACERS (2)
- CABLE CLAMP
- CLAMP BASE
- CLAMP SPACERS (2)

SIDE MOUNT 165-508-009

2.5 inches (64 mm) wide SIDE PLATES; ONE CABLE. For cowl, instrument panel, seat riser, or frame installation. No cable support.

Side Mount 165-508-009

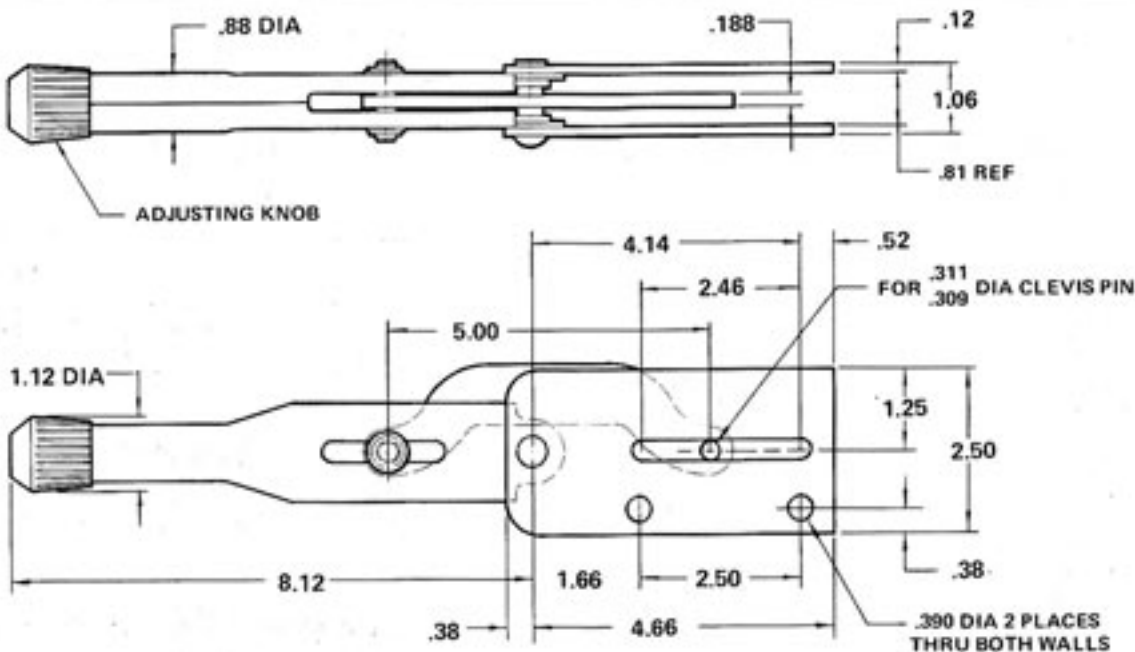

SUPPLIED WITH THE FOLLOWING HARDWARE:

- CLEVIS PIN
- COTTER PIN
- WASHER
- MOUNTING SPACERS (2)

ADJUSTABLE OVERCENTER-LOCKING BRAKE LEVERS

MOUNTING CONFIGURATIONS

SIDE MOUNT 165-508-011

1.5 inches (38mm) wide SIDE PLATES; ONE CABLE. For cowl, instrument panel, seat riser or frame installation.

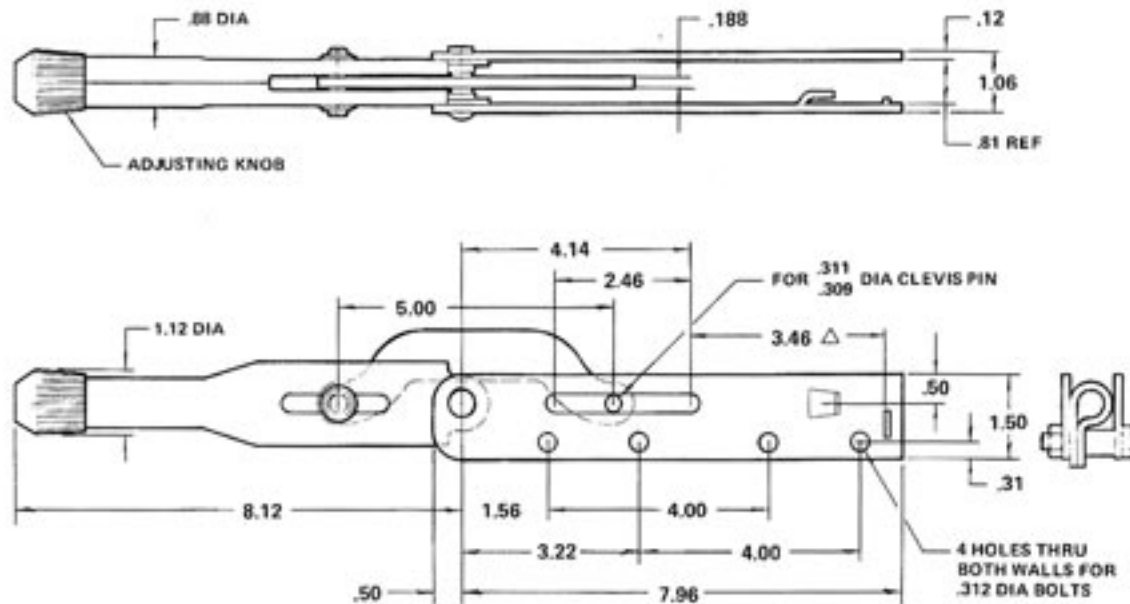

SUPPLIED WITH THE FOLLOWING HARDWARE:

- CLEVIS PIN
- COTTER PIN
- WASHER
- MOUNTING SPACERS (2)
- CABLE CLAMP
- CLAMP SPACER

Side Mount 165-508-0011

SIDE MOUNT 165-508-028

1.5 inches (38mm) wide SIDE PLATES; ONE CABLE. For cowl, instrument panel, seat riser, or frame installation.

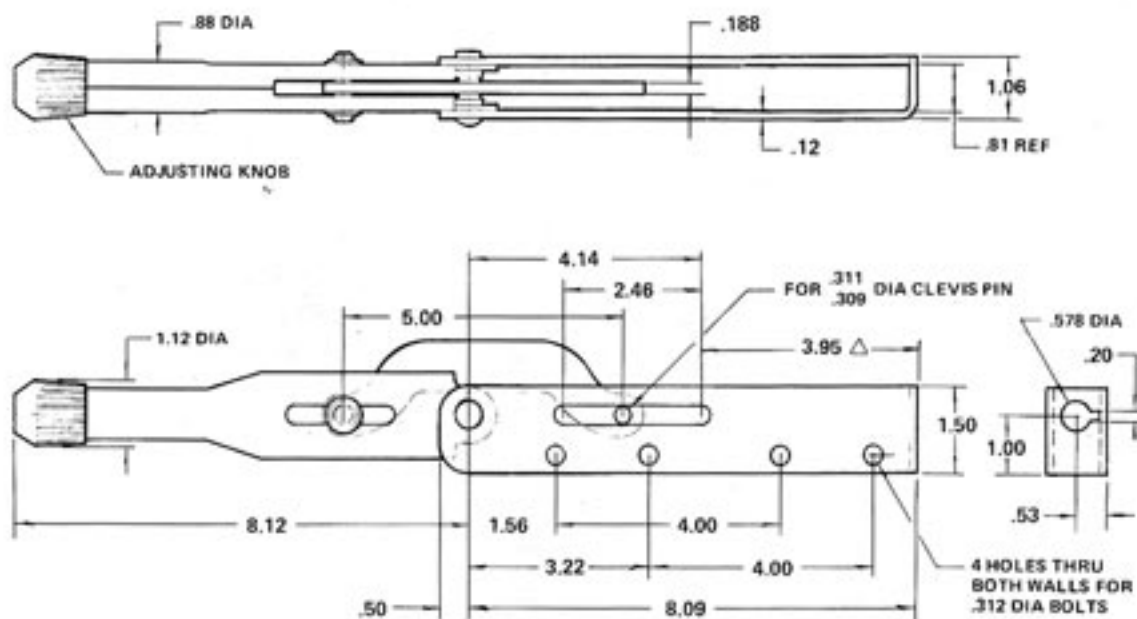

SUPPLIED WITH THE FOLLOWING HARDWARE:

- CLEVIS PIN
- COTTER PIN
- WASHER
- MOUNTING SPACERS (2)

Side Mount 165-508-028

MOUNTING CONFIGURATIONS

FLANGE MOUNT-RIGID 165-508-010

2.5 inches (64mm) wide SIDE PLATES; ONE CABLE. For bulkhead, floor or island (doghouse) installation. The rigid frame maintains alignment of clevis pin guide slots for improved life of both the pin and side plates.

Flange Mount-rigid 165-508-010

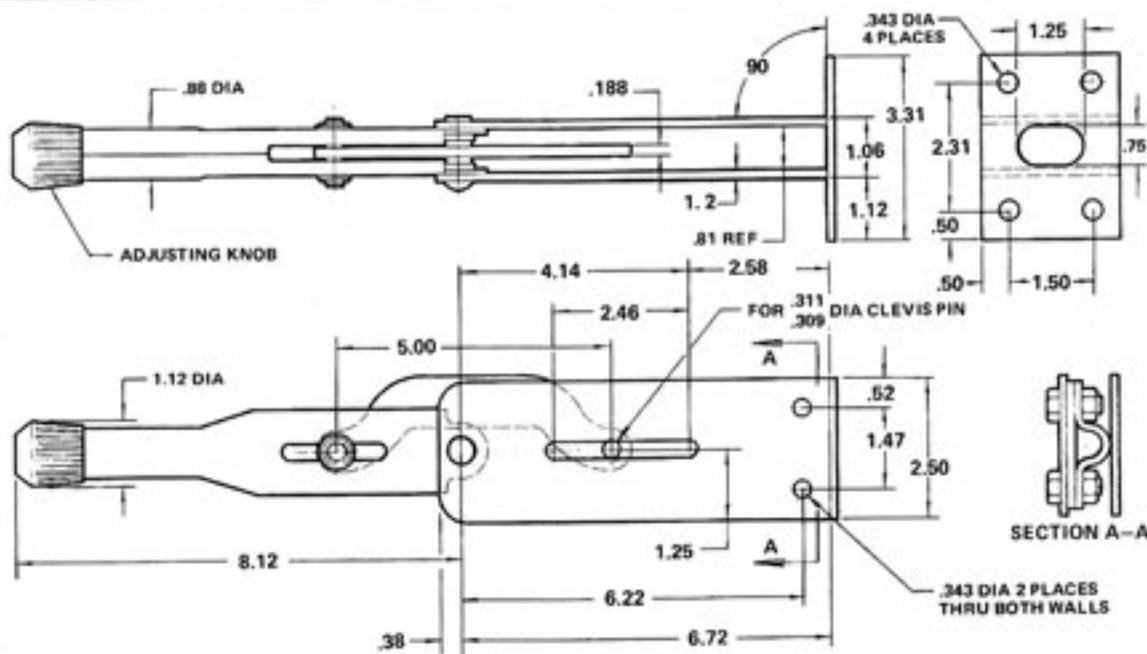

SUPPLIED WITH THE FOLLOWING HARDWARE:

- CLEVIS PIN
- COTTER PIN
- WASHER
- CABLE CLAMP
- CLAMP BASE
- 5/16-24 BOLTS (2)
- 5/16-24 NUTS (2)

FLANGE MOUNT 165-508-078

2.5 inches (64 mm) wide SIDE PLATES; ONE CABLE. For bulkhead, floor, or island (doghouse) installation. Angle wing flange mounting.

Flange Mount-rigid 165-508-078

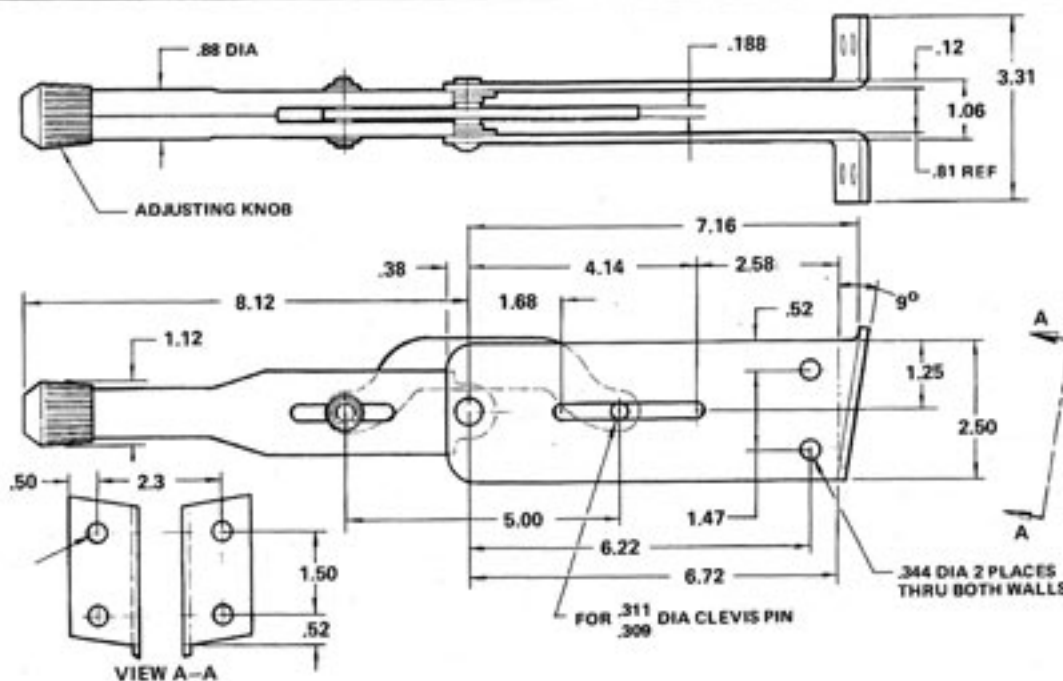

SUPPLIED WITH THE FOLLOWING HARDWARE:

- CLEVIS PIN
- COTTER PIN
- WASHER
- CABLE CLAMP
- CLAMP BASE
- 5/16-24 BOLTS (2)
- 5/16-24 NUTS (2)

MOUNTING CONFIGURATIONS

SIDE MOUNT-DUAL OUTPUT* 165-508-013

2.5 inches (64mm) wide SIDE PLATES; TWO CABLES. For cowl, instrument panel, seat riser, or frame installation. NOTE: When considering load requirements, the load on the lever assembly will be the sum of the load in each cable.

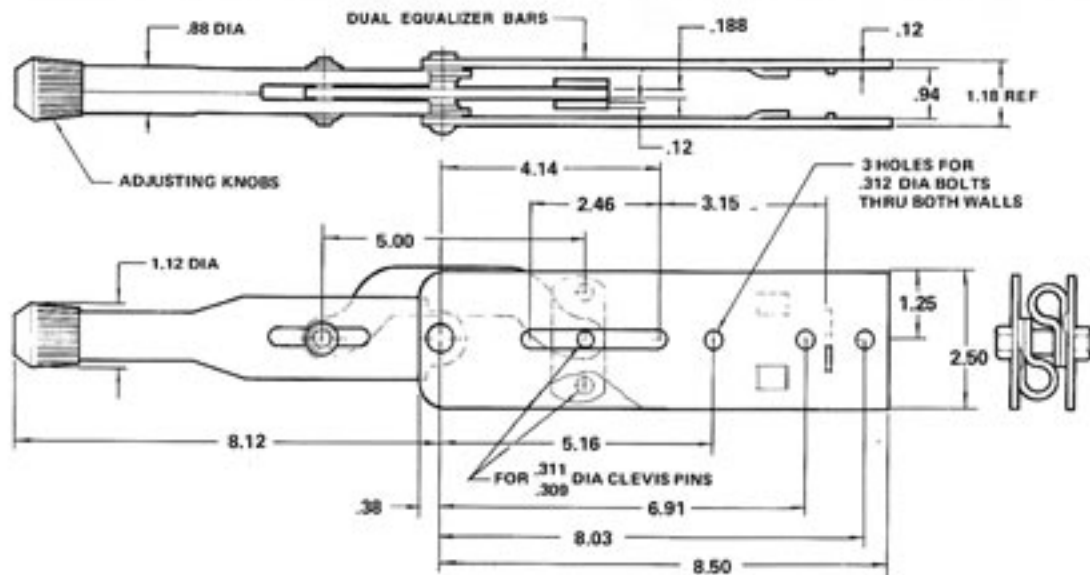

SUPPLIED WITH THE FOLLOWING HARDWARE:

- CLEVIS PINS (2)
- COTTER PINS (2)
- WASHERS (2)
- MOUNTING SPACERS (2)
- CABLE CLAMPS (2)
- CLAMP SPACER

Side Mount-dual output 165-508-013

FLANGE MOUNT-DUAL OUTPUT* 165-508-023

2.5 inches (64mm) wide SIDE PLATES; TWO CABLES. For bulkhead, floor, or island (doghouse) installation. NOTE: When considering the load requirements, the load on the lever assembly will be the sum of the load in each cable. Wing flange mounting.

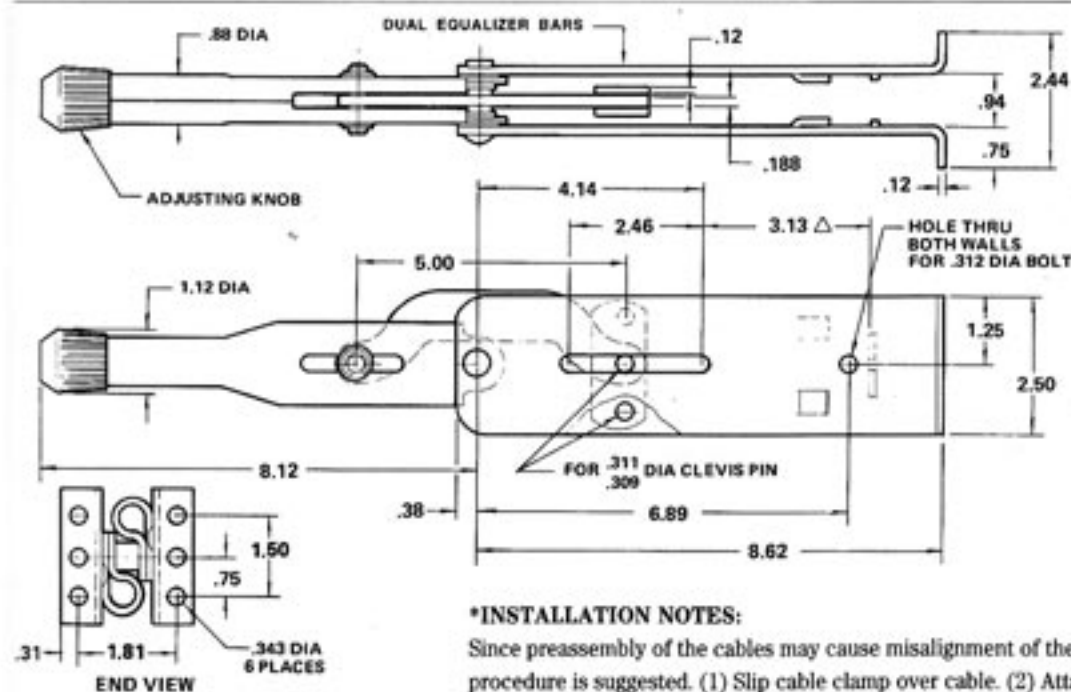

SUPPLIED WITH THE FOLLOWING HARDWARE:

- CLEVIS PINS (2)
- COTTER PINS (2)
- WASHERS (2)
- MOUNTING SPACERS (2)
- CABLE CLAMPS (2)
- CLAMP SPACER

*INSTALLATION NOTES:

Since preassembly of the cables may cause misalignment of the side plates, the following installation procedure is suggested. (1) Slip cable clamp over cable. (2) Attach cable clevis to equalizer bars with clevis pins and hardware provided. (3) Install cable clamp spacer and lightly tighten the 5/16 bolt. (4) Install lever assembly to the vehicle, tighten for fit only—DO NOT TORQUE. (5) Finish tightening the cable clamp bolt. (6) Complete installation by tightening the mounting bolts.

Flange Mount-dual output 165-508-023

Accelerator Control Systems

from
Cablecraft



Our throttle control mechanism is an ideal application for medium and heavy-duty trucks, construction and farm equipment, and buses. This is the complete package from the pedal to the accelerator system.

HELPS MEET FMVSS124

When properly installed, CABLECRAFT's system will aid you in meeting the requirement for Federal Motor Vehicle Safety Standard 124.

RUGGED ASSEMBLY AND CONSTRUCTION

Manufactured of corrosion resistant cast aluminum and plated steel parts with steel pivot and acetal bearings, the pedal system is designed for smooth operation and long life.

A protective rubber boot keeps dirt from entering through floor linkage and seals against the outside environment. The top face of the pedal is heavily ribbed for strength.

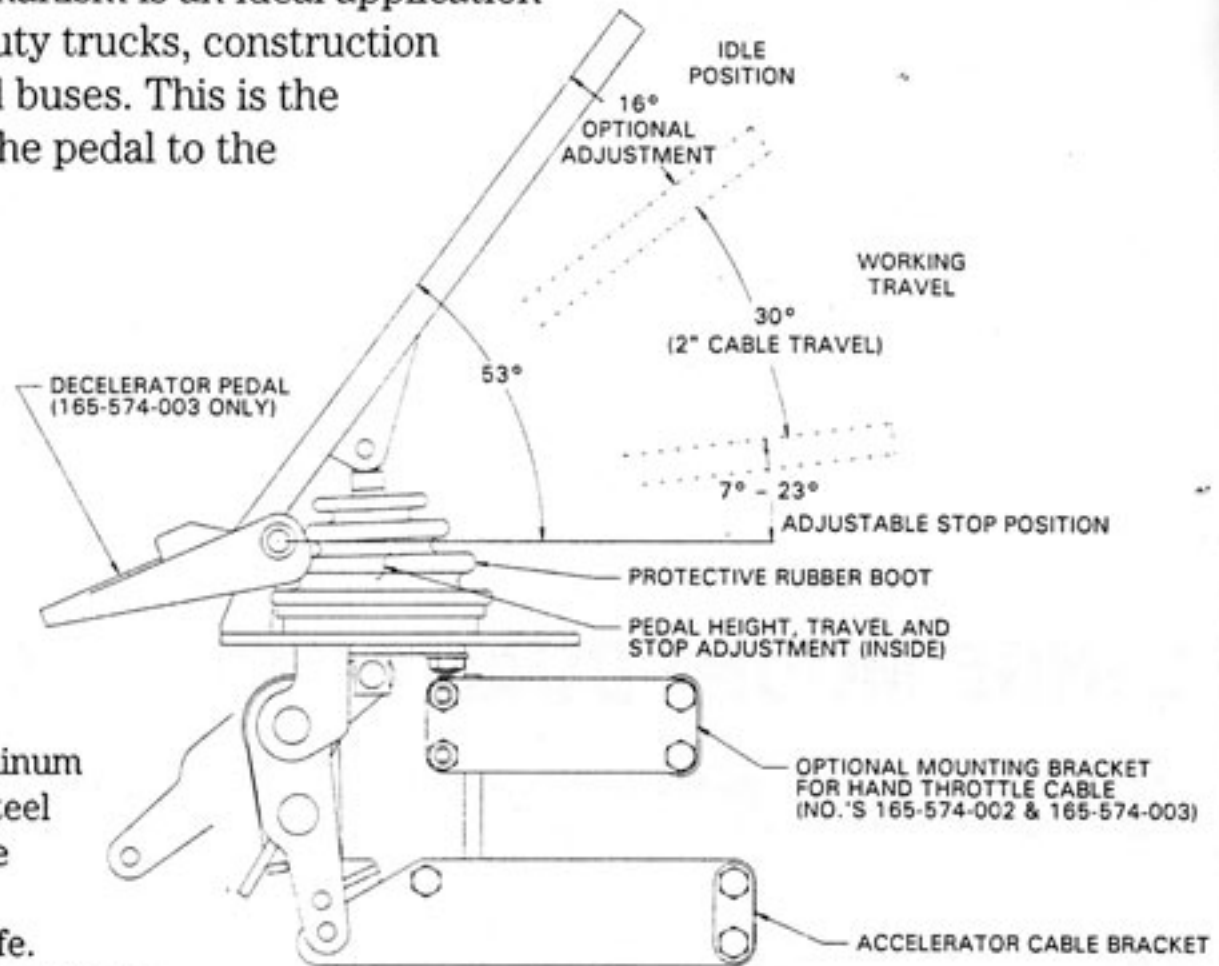

FAST AND ECONOMICAL INSTALLATION

A CABLECRAFT throttle cable simplifies the installation, providing a complete system to suit many applications.

The pedal lower mechanism is designed to be dropped through the floor and secured. Cable attachment can then be quickly and easily completed.

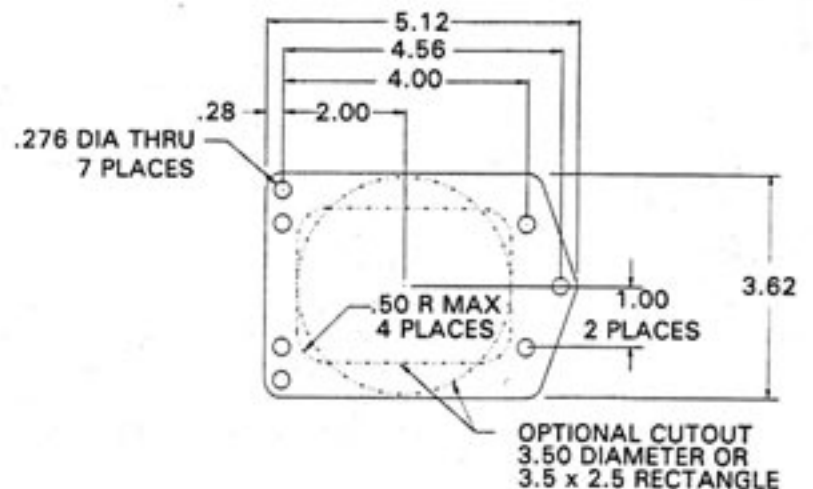

Three Models to Satisfy Most Pedal Requirements

- Standard Pedal provides pull-only action for positive engine control.
- Standard Pedal with hand throttle option.
- Accelerator/Decelerator allows temporary deceleration with a touch of the foot.

Pedal start position can be adjusted to allow a comfortable foot position. Total pedal movement at full travel is 30 degrees and gives a cable movement of 2.00".

An adjustable stop is incorporated under the flexible protective boot. This adjustment must be set to avoid excessive loads being placed on the assembly.

Part Number 165-574-001

Standard Pedal

For use with one pull-only accelerator cable.

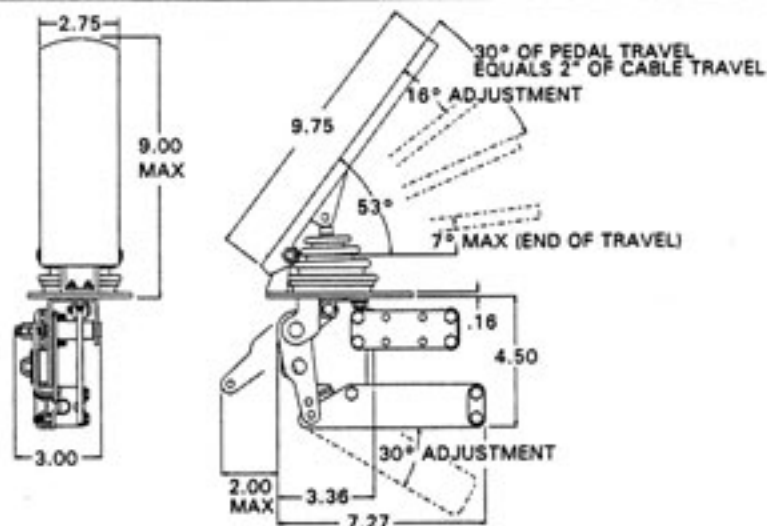
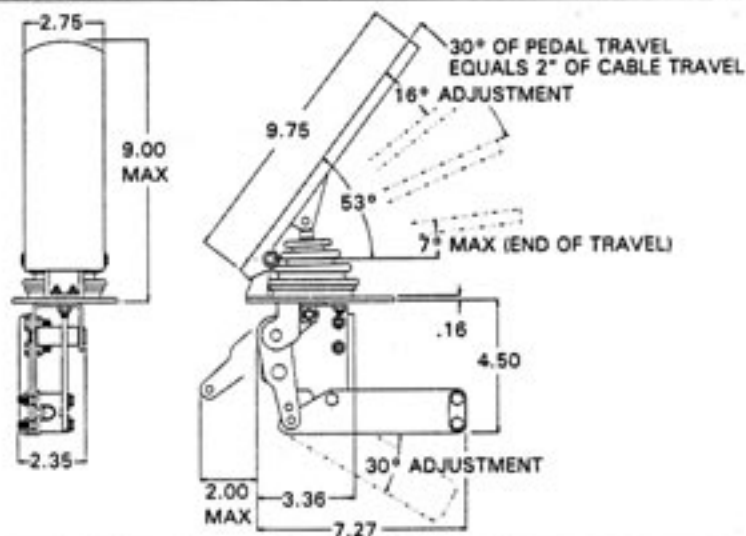

Part Number 165-574-002

Standard Pedal

With an additional cable mounting bracket for use with a hand throttle.

Part Number 165-574-003

Accelerator/Decelerator

Includes all features of the hand throttle version plus an added heel plate for quick temporary deceleration from any throttle setting.

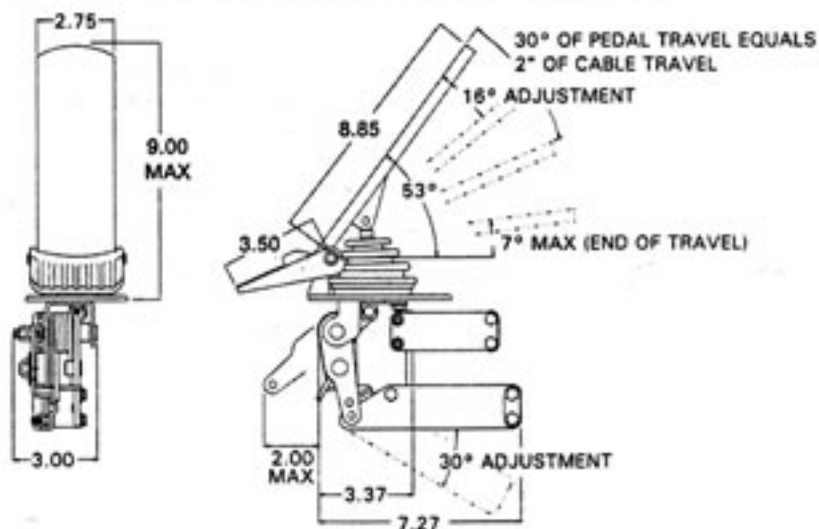

Medium-Duty Throttle

Applications:

- Farm machinery
- Heavy machinery
- Landscaping equipment
- Construction equipment
- Warehouse equipment

Features:

- Steel construction
- Rear or front throttle connection
- Multiple base bolt patterns
- Spring returned pedal
- Travel: 3.00" maximum
- -25°F —160°F temperature range (-14°C — 90°C)
- Coated sheet metal components
- Embossed pedal surface reduces slippage

Material:

- Coated sheet metal
- Plastic bushings
- Plastic boot plated steel hardware



Medium-Duty Pedal CH530

For use with single pull-only throttle (gas) cables.

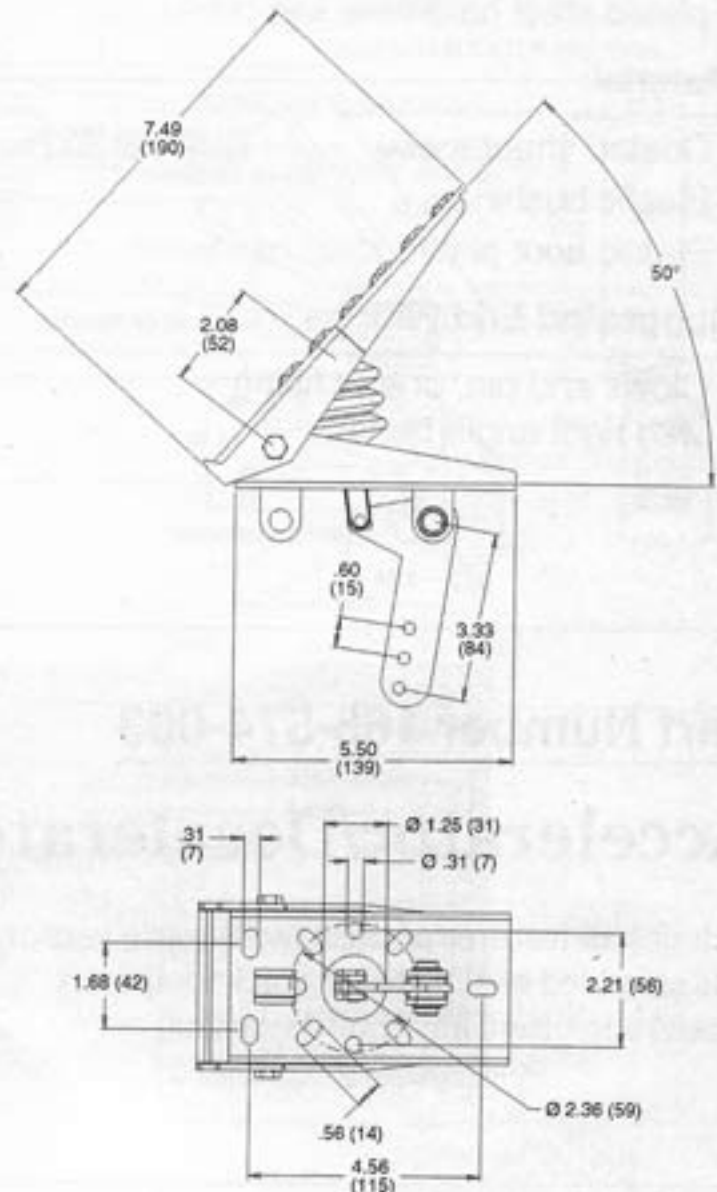

Fast and Economical Installation

A throttle cable simplifies the installation, providing a complete system to suit many applications.

The pedal tower mechanism is designed to be dropped through the floor and secured. Cable attachment can then be quickly and easily completed.

HEAVY DUTY CONTROL LEVER

PART 165-041-002

- VERSATILE
- CUTS COST
- FITS ANYWHERE

Makes simpler installations and easier action on hard-to-move remote valves, clutches, brakes, shifters.

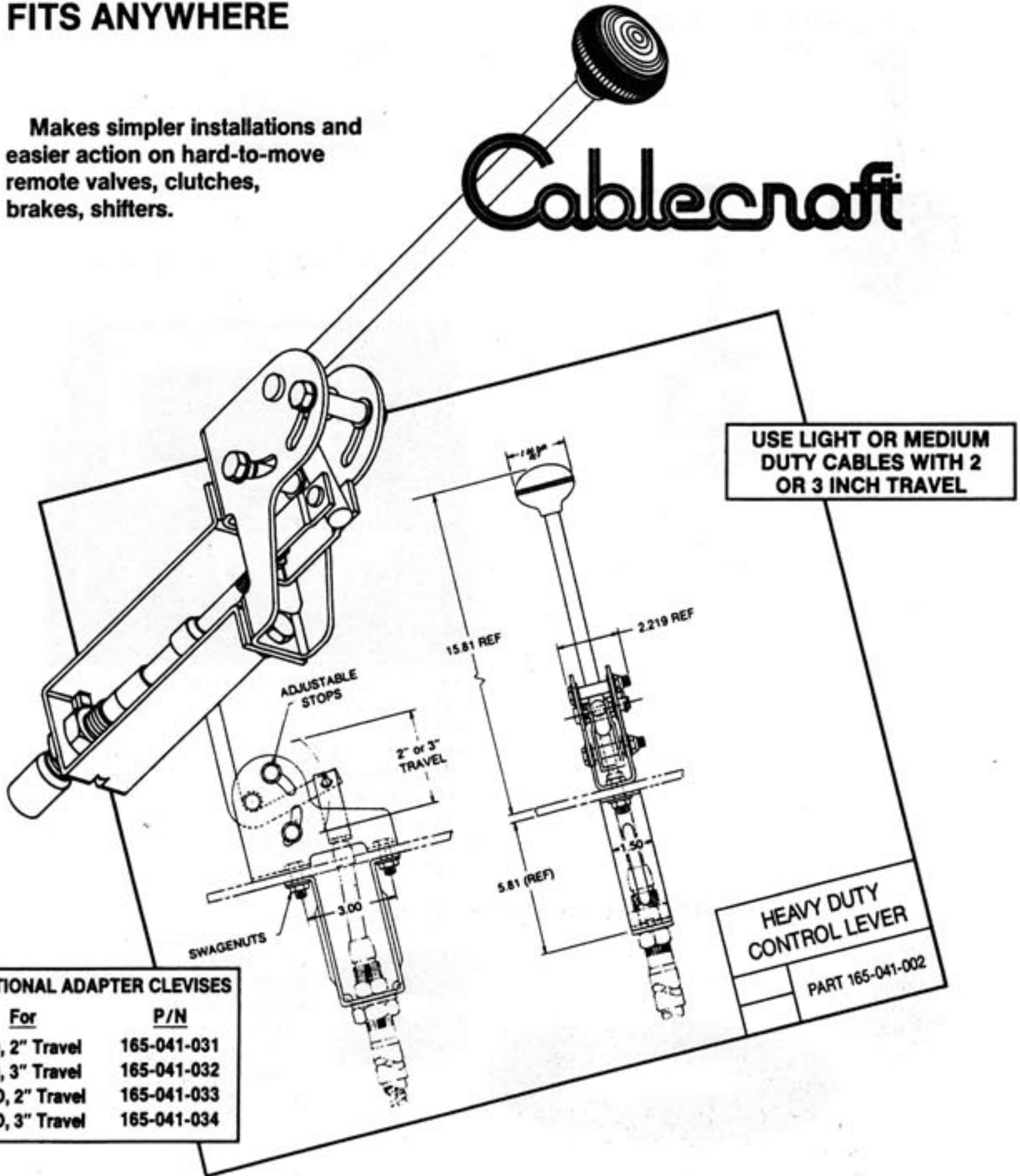

OPTIONAL ADAPTER CLEAVISES

For	P/N
LD, 2" Travel	165-041-031
LD, 3" Travel	165-041-032
MD, 2" Travel	165-041-033
MD, 3" Travel	165-041-034

CONTROL SYSTEMS

LOCKOUT AIR VALVE KITS



NEUTRAL LOCKOUT AIR VALVE KIT
PART NO. K101AS
NEUTRAL LOCKOUT/FEATHERING AIR
VALVE KIT
PART NO. K101FAS

DUAL PRESSURE CONSOLE SYSTEM



AIRCONTROL EITHER HIGH OR LOW
PRESSURE SYSTEM.
KIT CONTAINS
4WAY TOGGLE VALVE
2PRESSURE SWITCHES
2INDICATOR LIGHTS
ALL TUBING AND FITTINGS
BLACK STEEL CONSOLE

TOGGLE STYLE AIR VALVE KIT

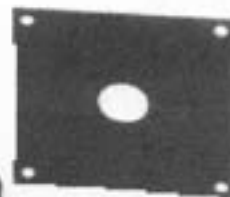

KIT CONTAINS;
BRASS SPRING RETURN
AIR FEATHERING
VALVE
25' X1/4 D.O.T TUBING
CONSOLE ADAPTER
FINGER GUARD

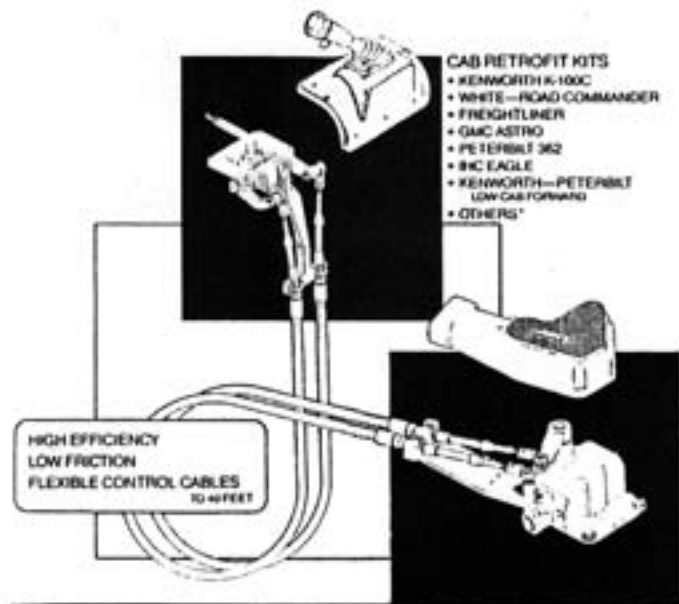

CAB RETROFIT KITS
 • KENWORTH K-100C
 • WHITE—ROAD COMMANDER
 • FREIGHTLINER
 • GMC ASTRO
 • PETERBILT 362
 • IHC EAGLE
 • KENWORTH—PETERBILT
 LOW CAB FORWARD
 • OTHERS*

“QUICK STIK” RETROFIT KITS UPGRADE YOUR COE TO CURRENT STANDARDS

Reduces maintance requirements

Increases driver comforts

Increase profits

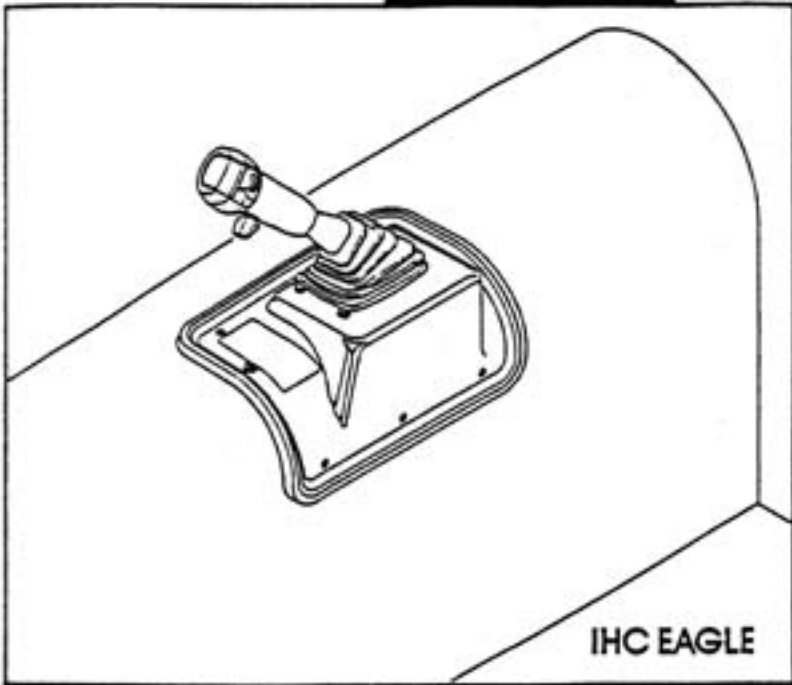

IHC EAGLE

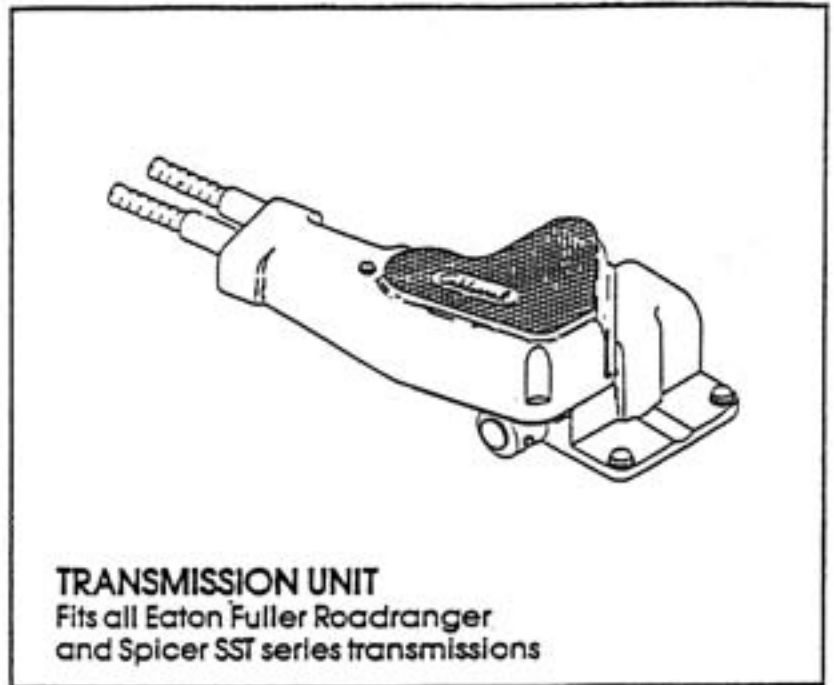

TRANSMISSION UNIT
 Fits all Eaton Fuller Roadranger
 and Spicer SST series transmissions

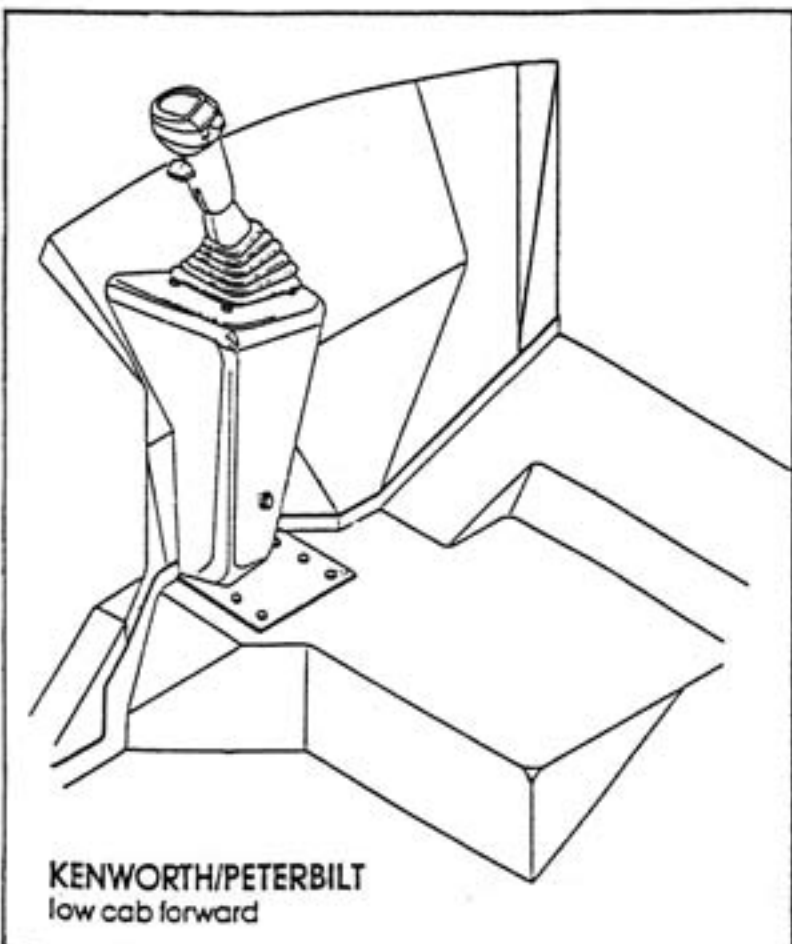

KENWORTH/PETERBILT
 low cab forward

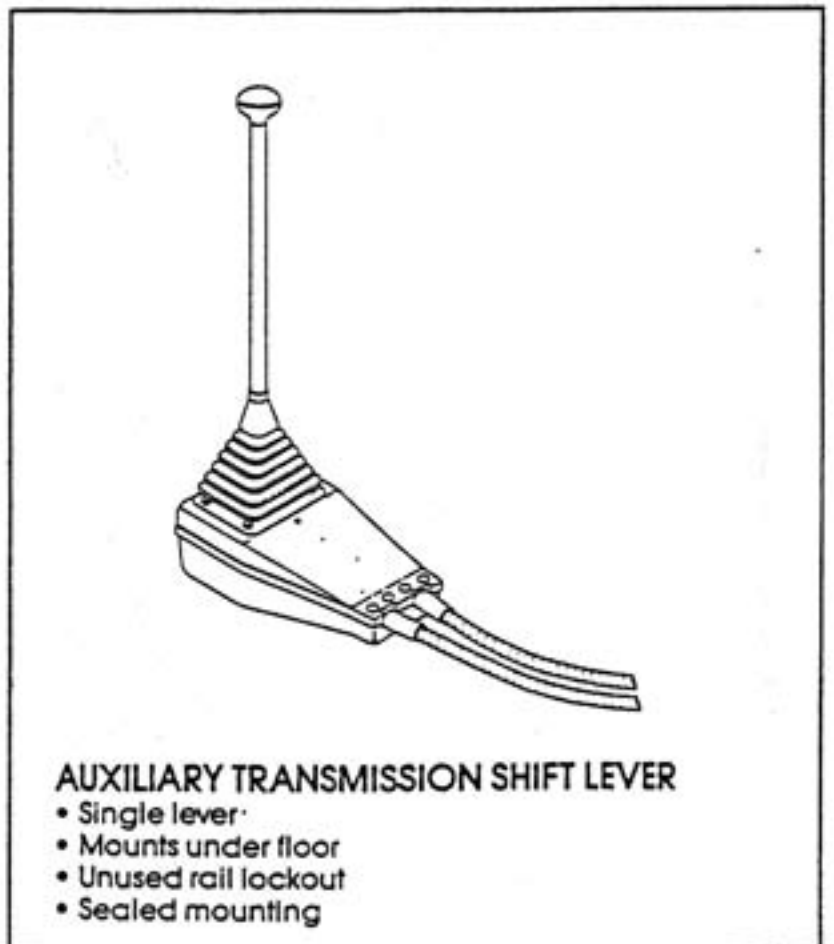

AUXILIARY TRANSMISSION SHIFT LEVER
 • Single lever
 • Mounts under floor
 • Unused rail lockout
 • Sealed mounting

MTS (Manual Transmission System) "Quik Stik" cables

Replacements for Cablecraft's cable operated manual transmission shift system.

Order Code: X=3 for stainless end rods with mod 6 seals.

X=4 for stainless support tubes and end rods with mod 6 seals

L=Length

Part No. A31X-105-L Grooved-Grooved

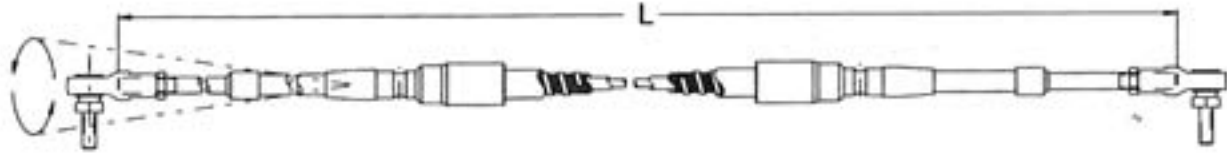

Part No. A31X-106-L Same as -105 but with an umbrella seal



Part No. A31X-113-L Grooved-Threaded



Unidrum Lever Control Replacement Cables

Part No. A17X-330 Grooved

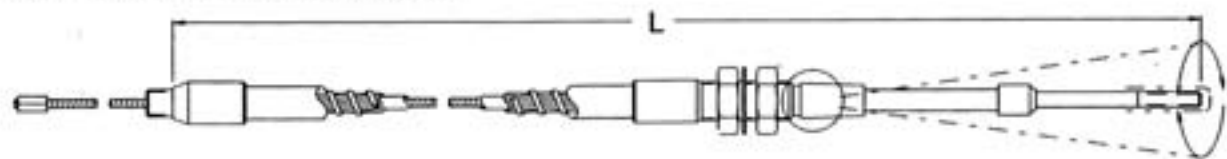

Part No. A17X-332 Threaded

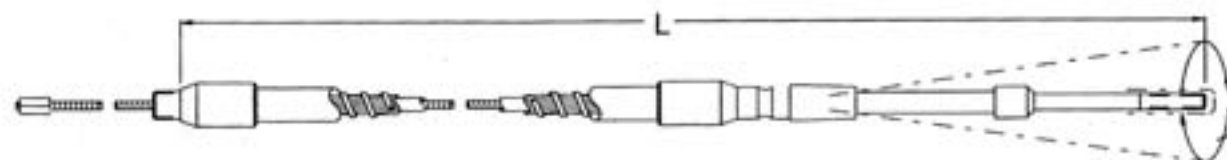

Modulator Cables

Modulator and cable interconnect Allison® automatic transmission with engine fuel control. Modulator can be set to either "push" or "pull" to operate.

Cablecraft modulator unit and cable

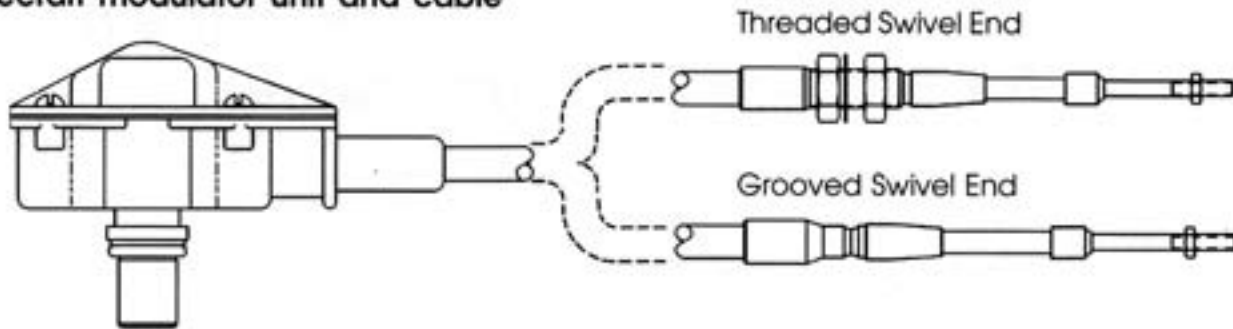

CABLE OUTPUT END	MODULATOR UNIT WITH CABLE		REPLACEMENT MODULATOR BOX
	PULL TO OPERATE	PUSH TO OPERATE	
GROOVED MOUNT			
173 UTILITY	CA 343-001-L	CA 343-002-L	P/N 165-900
174 UTILITY	CA 345-001-L	CA 354-002-L	
THREADED MOUNT			
173 UTILITY	CA 343-001-L	CA 342-002-L	SLIP CLEVIS P/N AC-310
174 UTILITY	CA 341-001-L	CA 341-002-L	

Replacement Cables for Cablecraft modulator

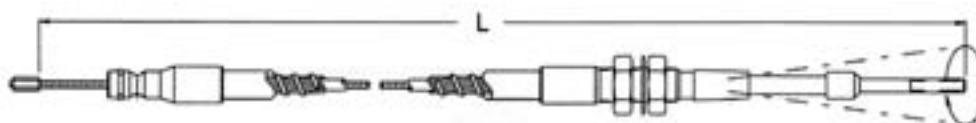

CABLE ONLY PART NO.	CABLE OUTPUT END
	THREADED MOUNT
CA 342-000-L	173 UTILITY
CA 341-000-L	174 UTILITY



CABLE ONLY PART NO.	CABLE OUTPUT END
	GROOVED MOUNT
CA 343-000-L	173 UTILITY
CA 345-000-L	174 UTILITY

Replacement Cables for other USA manufactured modulator



CABLE ONLY PART NO.	CABLE OUTPUT END
	THREADED MOUNT
CA 212-T-L	173 UTILITY
CA 213-T-L	174 UTILITY

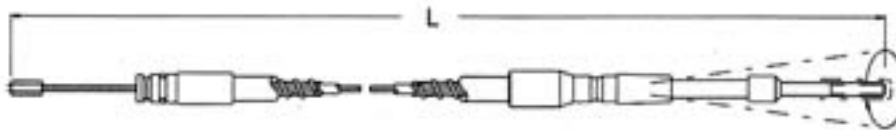

CABLE ONLY PART NO.	CABLE OUTPUT END
	GROOVED MOUNT
CA 212-G-L	173 UTILITY
CA 213-G-L	174 UTILITY

HYDROBACK*

*A unique self-centering mechanism
for push-pull control cables.*

The HYDROBACK:

- especially useful for centering controls on
Hydrostatic Transmissions
Non-detented Hydraulic Valves
- Mounts directly on standard push-pull cables
- Eliminates bulky dual-spring systems and extra
brackets and levers
- Protected linkage for safer operation

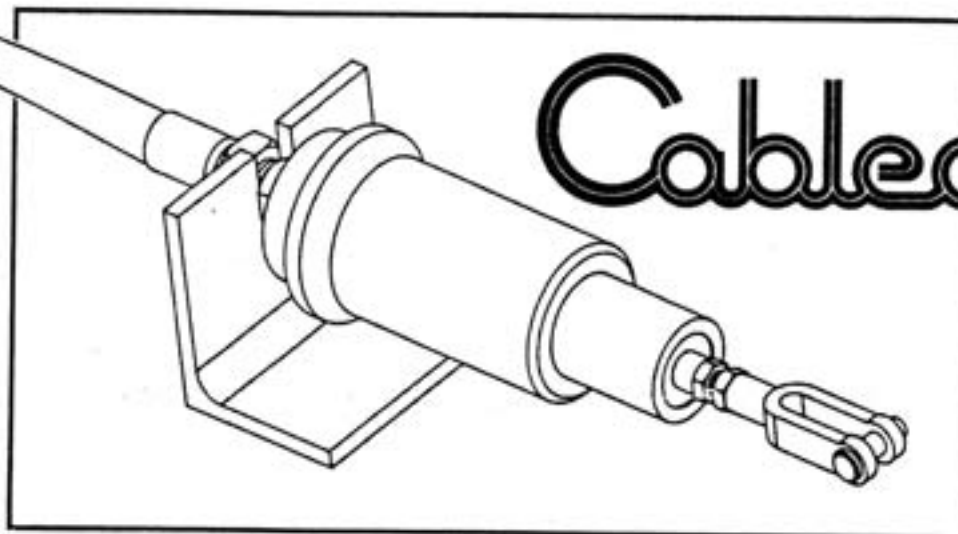

- Economical
- Rugged
- Compact
- Adjustable
- Safe
- Dependable

Ordering Code

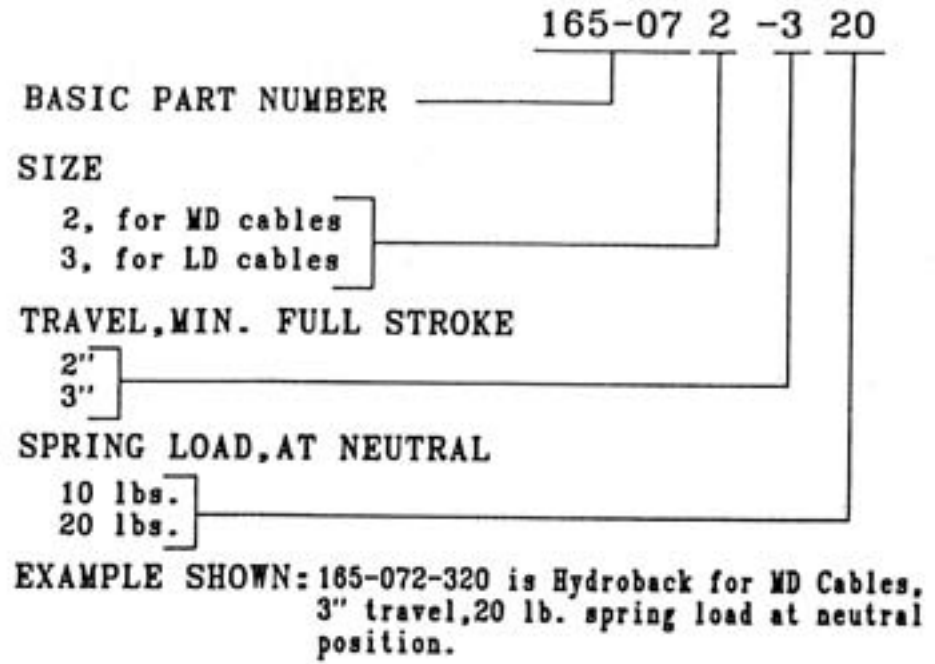

Dimensional Data All Dimensions Are In Inches.

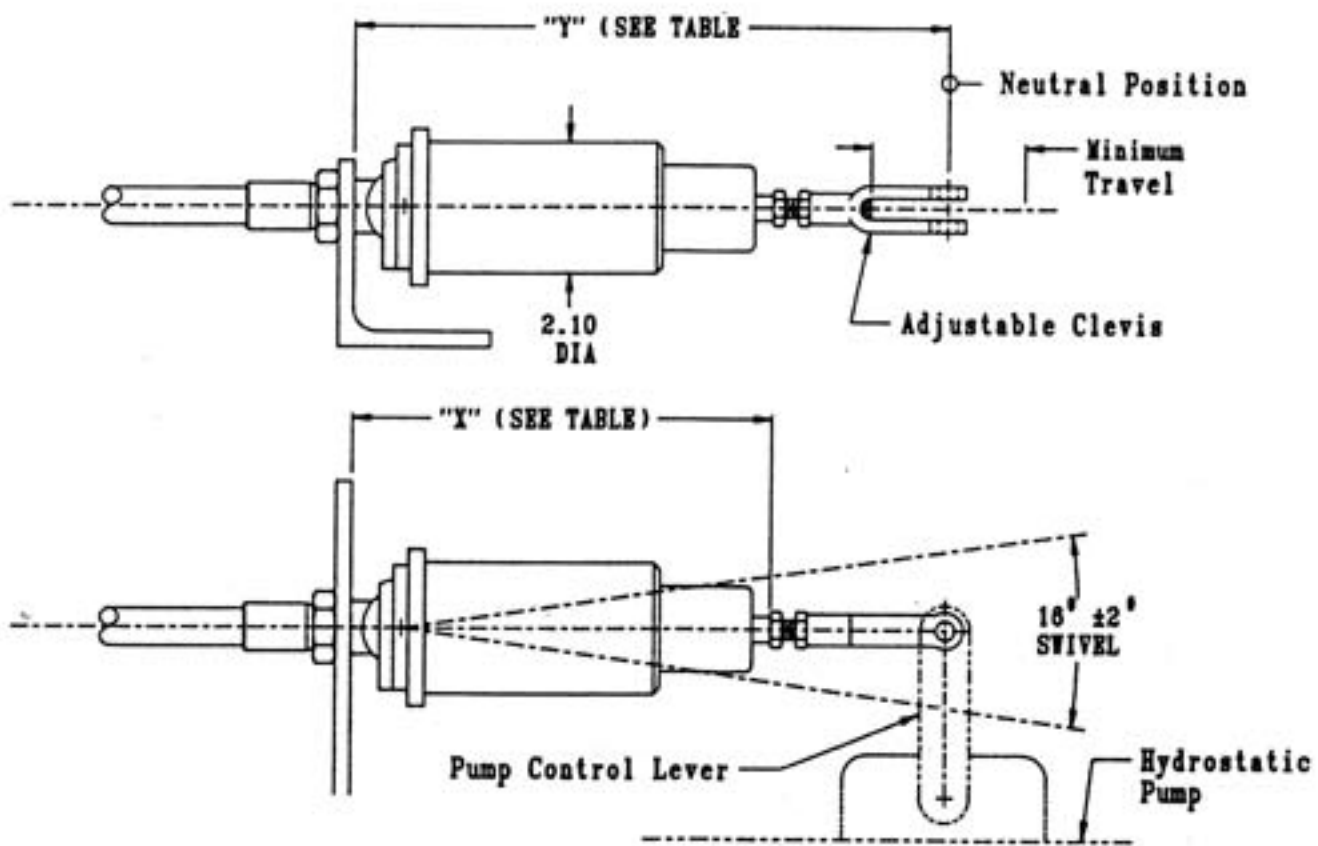

Cable Size	Travel	Part Number	Recommended Clevis	"X"	"Y"	
					Min	Max
LD	2.00	165-073-2 lb.	AC 206	5.63	7.63	7.87
	3.00	165-073-3 lb.	AC 206	7.03	8.03	8.27
MD	2.00	165-072-2 lb.	AC 212	5.63	7.88	8.20
	3.00	165-072-3 lb.	AC 212	7.03	9.28	9.60

Cablecraft's Unidrum Control Lever, the Choice of Professionals

- Hold and operate up to 25 lb. push/pull or pull-only output load. Mechanical advantage at knob is 5/1.
- Self-locking nut for operator adjustment of friction setting.
- Adjustable stop plates allow 10 degree ($3/16$ " linear output) incremental travel adjustment. 2" of cable travel requires 106 degree lever travel. 3" of cable travel requires 160 degree lever travel.
- Lever position is adjustable in 60 degree increments to provide optimum operating range.
- Optional cable entry offers four mounting and direction of operation alternatives.
- Rugged diecast zinc alloy material.
- Mount with (4) $3/16$ " screws or bolts.

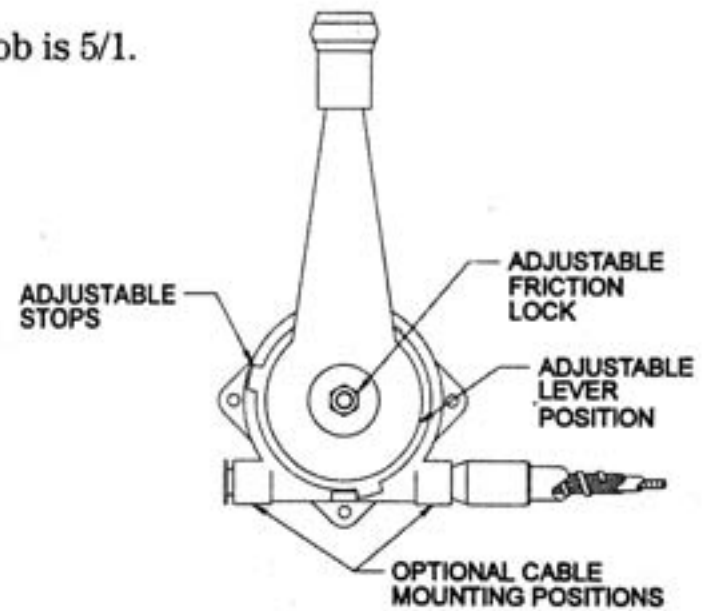

Side Mount

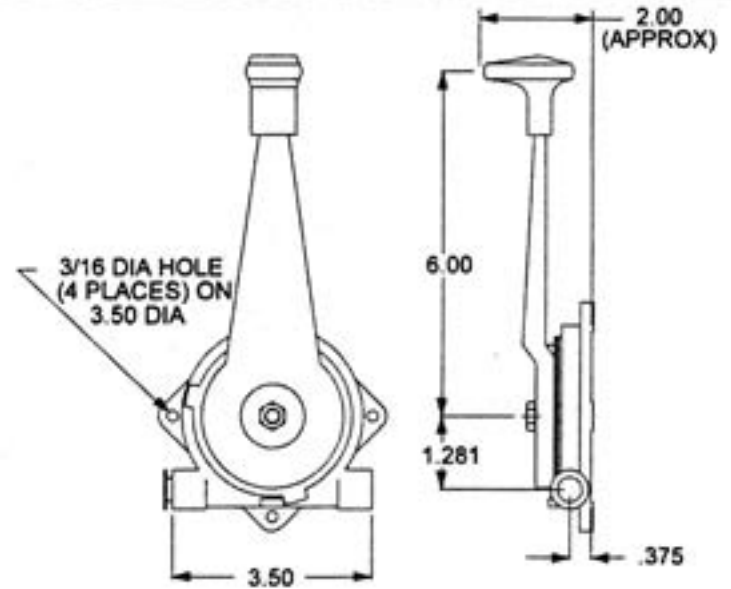
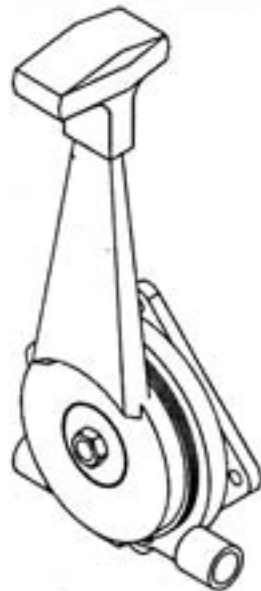

Base Mount Accessory

BASE MOUNT ACCESSORY

Converts a standard side mount UNIDRUM lever to a free-standing, base-mounted lever. For use on horizontal panels or surfaces.

Made from $1/8$ " steel and zinc-coated for weather resistance. Mounts to the UNIDRUM lever with four $3/16$ "x $5/8$ " bolts (not furnished with this bracket).

ORDER PART NUMBER 165-506-003

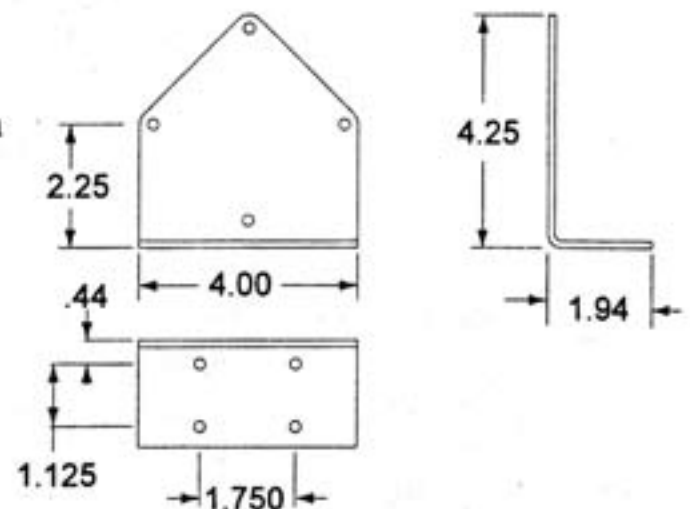

Ordering Code For Unidrum Controls

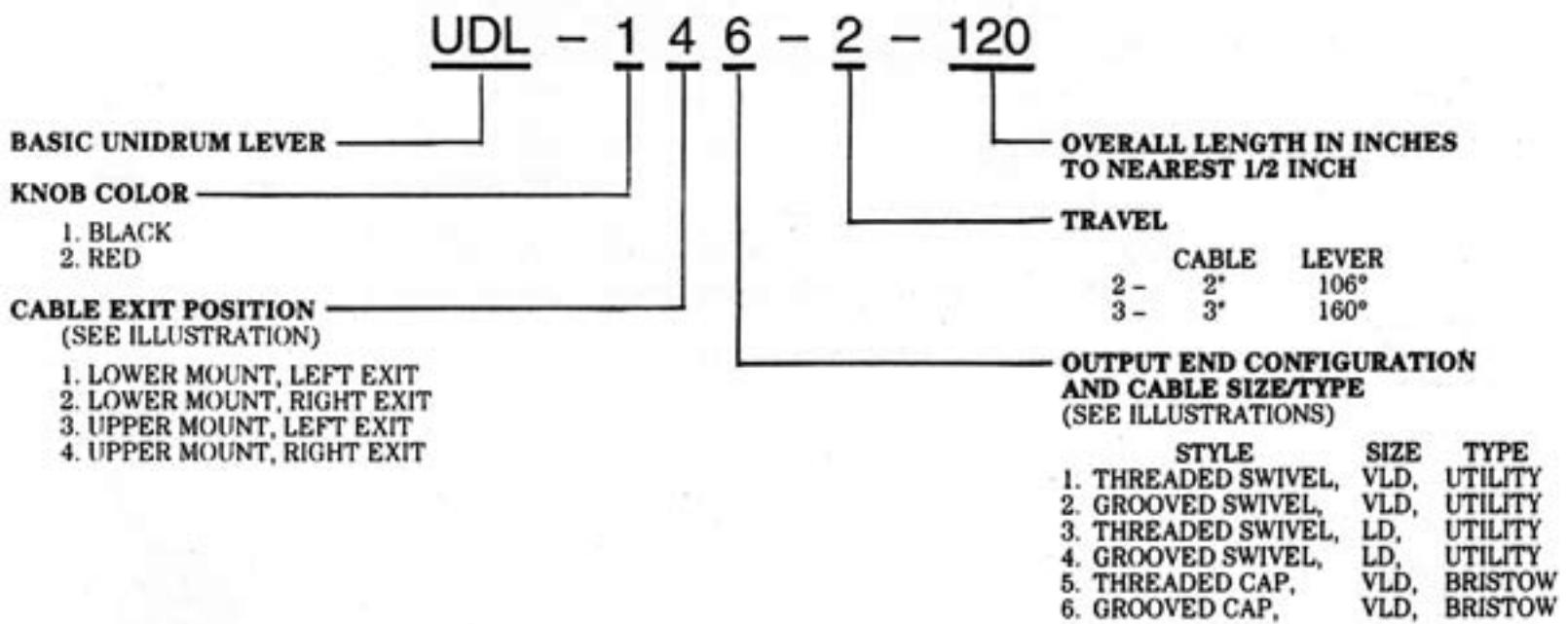

CABLE EXIT POSITIONS

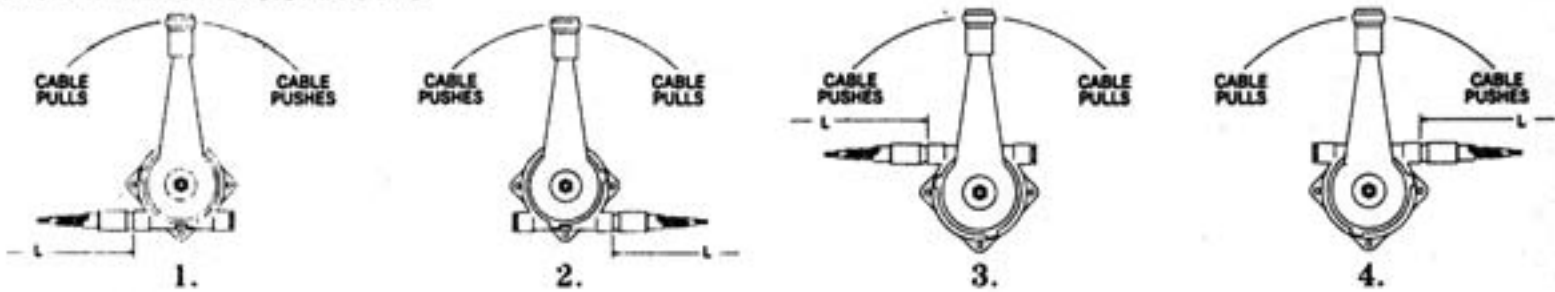

Exit Positions

CABLE OUTPUT END FITTINGS

	Threaded Swivel "T"	Dimension A	Grooved Swivel "G"	Dimension A
VLD UTILITY		Per Stroke (extended)		Per Stroke (extended)
		2" 6.94		2" 6.25
		3" 8.94		3" 8.25
LD UTILITY		2" 7.18		2" 6.56
		3" 9.18		3" 8.56
VLD BRISTOW				
		5. (pull-only)		6. (pull-only)

Output End Fittings

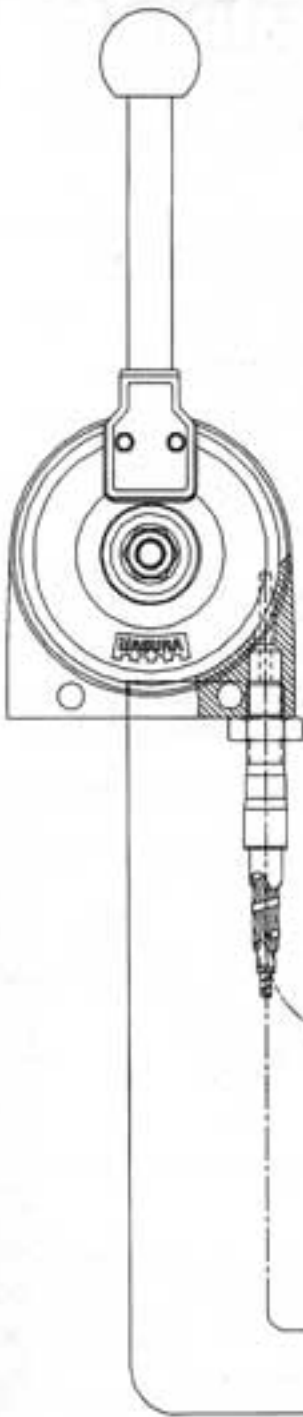

Model.....	22.3
Travel.....	3.15" (80mm)
Mechanical Advantage.....	1:4.5
Maximum Load.....	68lbs (300N)
A) Lever Angle.....	156°
B) Lever Length.....	6.30" (160mm)
C) Lever Offset.....	2.32" (59mm)

Detents at 0, 24.5, 49, 73.5mm of travel. Pushing down on spring loaded knob releases lever from detent

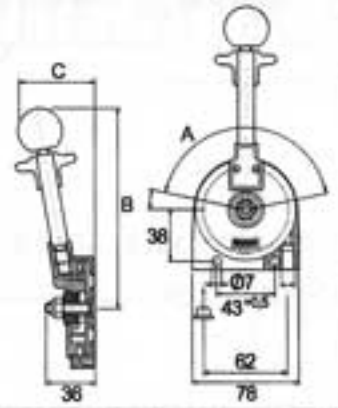

PART NO. CODE

CA 291 - X - XX - T - L

BASIC CONTROL ASSY
VERY LIGHT DUTY

LEVER TYPE
1 = 22.1
3 = 22.3

CABLE CONSTRUCTION
U = UTILITY
E = EXT

CONDUIT SWIVEL FITTING
T = THREADED
G = GROOVED

LENGTH
TRAVEL INCHES
1, 2, OR 3

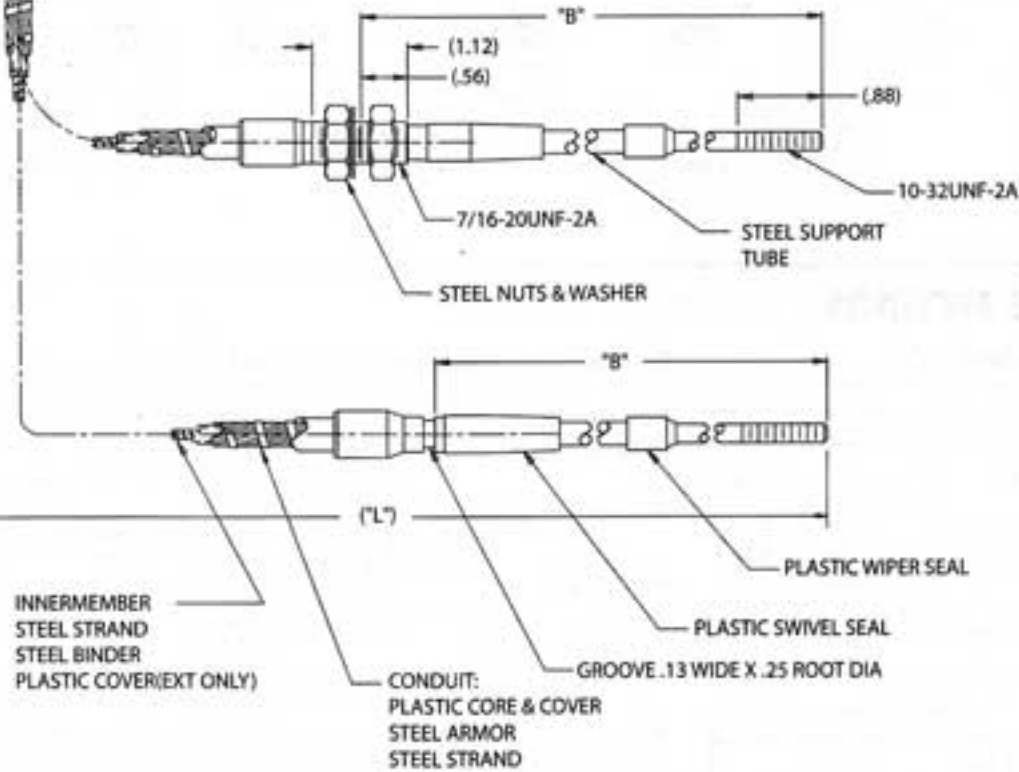

3	7.38
2	5.87
1	4.38
STROKE	"B"

THREADED SWIVEL CONDUIT FITTING

3	6.69
2	5.19
1	3.69
STROKE	"B"

GROOVED SWIVEL CONDUIT FITTING

MAGURA LEVERS

Model.....	22.1
Travel.....	3.15" (80mm)
Mechanical Advantage.....	1:4.5
Maximum Load.....	68lbs (300N)
A) Lever Angle.....	156°
B) Lever Length.....	5.75" (146mm)
C) Lever Offset.....	2.20" (56mm)

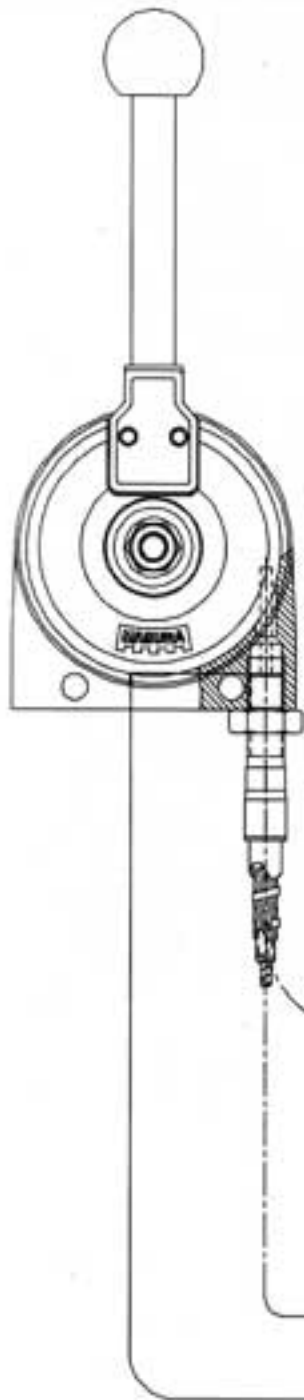
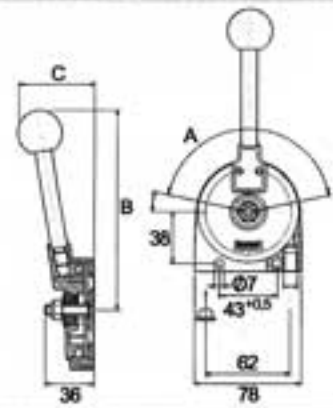

PART NO. CODE

CA 292 - X - XX - T - L

BASIC CONTROL ASSY
LIGHT DUTY

LEVER TYPE
1 = 22.1
3 = 22.3

CABLE CONSTRUCTION
U = UTILITY
E = EXT

CONDUIT SWIVEL FITTING
T = THREADED
G = GROOVED

LENGTH
TRAVEL INCHES
1, 2, OR 3

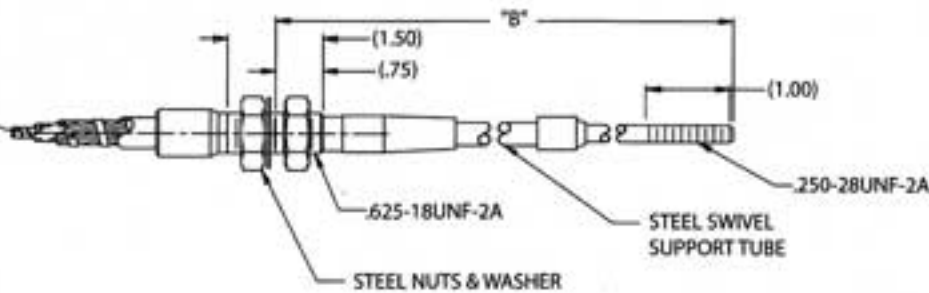

3	7.62
2	6.12
1	4.62
STROKE	"B"

THREADED SWIVEL
CONDUIT FITTING

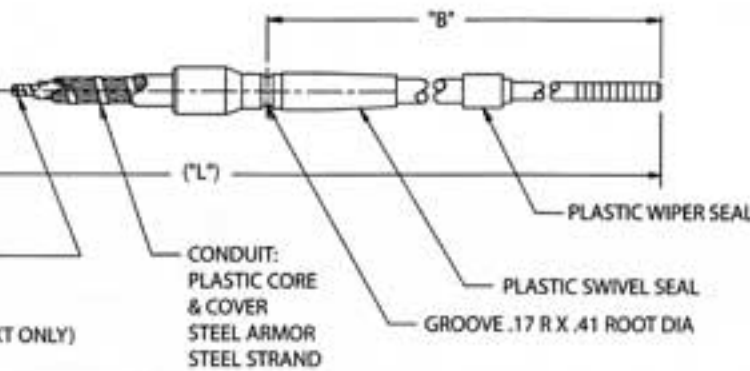

3	7.00
2	5.50
1	4.00
STROKE	"B"

GROOVED SWIVEL
CONDUIT FITTING

Travel can be limited symmetrically or asymmetrically, on both 22.1 and 22.3 levers, 10/20mm using coiled spring pins (sold separately).

Coiled spring pin:
P/N 175-420-034



Pin in:	Travel:	Travel course:
1 or 8	40mm	asymmetrical
2 or 7	50mm	asymmetrical
3 or 6	60mm	asymmetrical
4 or 5	70mm	asymmetrical
4 + 5	60mm	symmetrical
3 + 6	40mm	symmetrical



QUADRASTAT CONTROLS

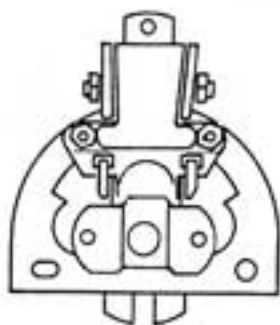

SELF-LOCKING

The QUADRASTAT® self-locking Control is a unique control lever that "locks where you leave it."

It automatically locks out feedback forces without using ratchets, gates, friction pads, or unlocking knobs. The operator never needs to make any preliminary unlocking

motion to reposition the lever. First used in high performance aircraft, the QUADRASTAT® Control is currently designed and manufactured as an economical anti-feedback device for use in a variety of agricultural and construction equipment applications.

The Q14 Series offers precise control, including backlash adjustment to assure ultimate performance throughout its life. The Q36 Series provides heavier load holding capability as well as the option of position detents.

THROTTLE

THROTTLE Controls on machinery requiring a constant power setting are one of the most common uses of QUADRASTAT® self-locking Controls. The QUADRASTAT® control is by far the most reliable and economical means of achieving a constant engine throttle setting. The Q14010 and Q14020 Series Controls are particularly compact lever assemblies.

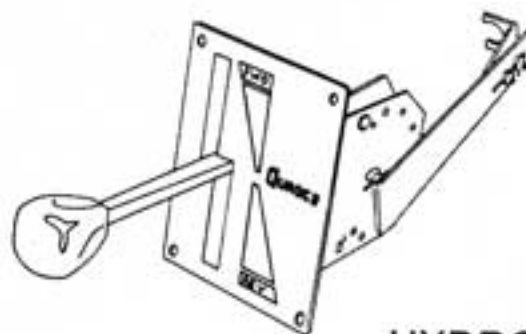

HYDROSTATIC

The versatility of the QUADRASTAT® control is demonstrated when used in the control of HYDROSTATIC TRANSMISSIONS.

The self-locking, anti-feedback feature provides an ideal means of positioning variable displacement pumps and motors. The locking unit may be fitted with a variety of standard input levers, linear or non-linear outputs, cable supports, bracket/housings, and gate plates, allowing the package to be tailored to meet the needs of each vehicle.

The T50 Series is typically used for a single pump or throttle control. The T60 Series has two Levers for use either as a combination pump and throttle control or a dual pump (motor) control package.

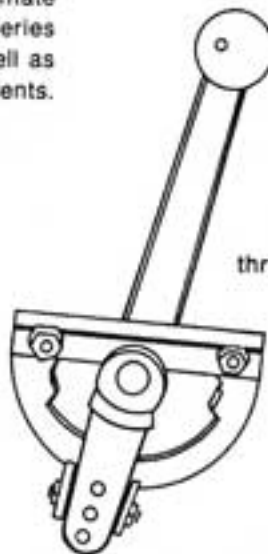

ELECTRONIC SHIFT CONTROL

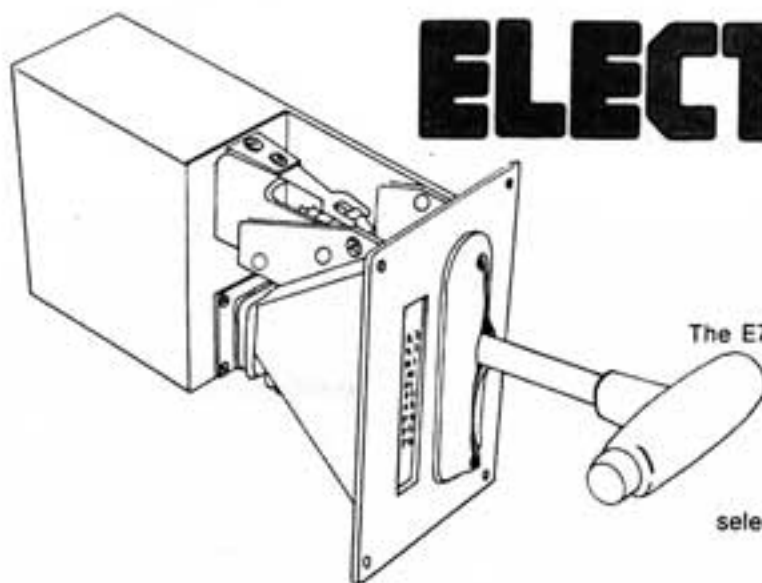

The E73 Series Control, designed with both electronic and switch options, meets the demand for an environmentally rugged, reliable, and cost effective Control of solenoid operated Transmissions. Electronic units may be programmed to provide such performance features as automatic torque converter lock-up, down shift inhibiting, automatic shifting, load/range selection, or other needs. Systems with proportional solenoids may be programmed using pulse width modulated outputs.

VALVE CONTROLS

SINGLE AXIS LEVER

The C80 Series Single Axis Lever Control provides precise, dependable remote control of high pressure hydraulic valves. The lever action is transmitted to the hydraulic valve by a standard push-pull cable of any type or make. The C80 does not limit the designer/owner selection in type or make of cable.

The Control is rugged, with oversized load bearing members. Cable loads exceeding 200 pounds are within its operating parameters. Multiple protection is provided for the cable by the lever boot, cable entry "O" ring, labyrinth housing seal, and the standard cable seal. Three standard lever lengths are offered, as well as four options of centering springs, (including none). Both the in-line C81 and right angle C82 models may be stacked for multiple valve operations.

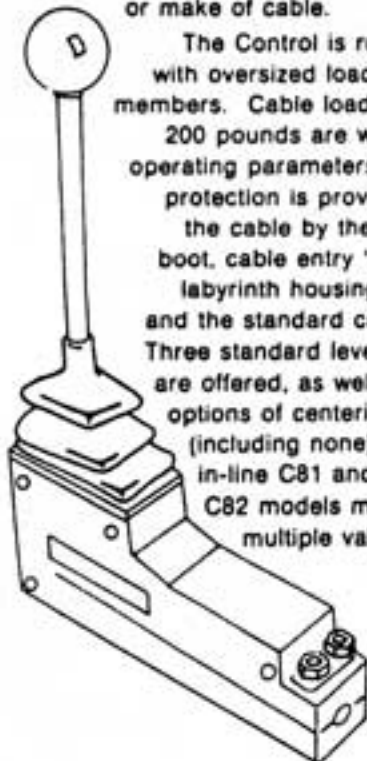

JOYSTICK

The C60 "JOYSTICK" or Dual Axis Control provides two symmetrical 1 inch stroke outputs with one input. Standard 1/4-28 or 5/16-24 Rod End push-pull cables or rod linkages may be used as the outputs. As the C60 is symmetrical, it may be oriented to obtain either a "+" or "X" operating mode. The output may be "tuned" by restricting the input with an internal gate plate. The input lever may be either a heavy rod with a ball knob for a 10:1 geometric advantage or an anatomic grip with switches to actuate additional functions.

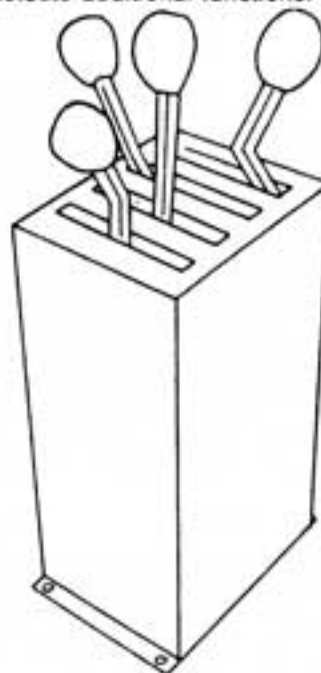

TRUCK BODY

TRUCK BODY and special purpose control levers use standard control housings, levers, and cable supports with dedicated gate plates to provide cost-effective control of such functions as P.T.O., HOIST, PLOW, AND PUP TRAILER DUMP VALVES.

HYDRAULIC REMOTE CONTROLS



Pilot-operated HYDRAULIC REMOTE CONTROLS provide for the precise "leather touch" control of hydraulic valves, pumps and motors. The use of low pressure hydraulics at the Control reduces noise, heat, leakage and effort, making the cab a more

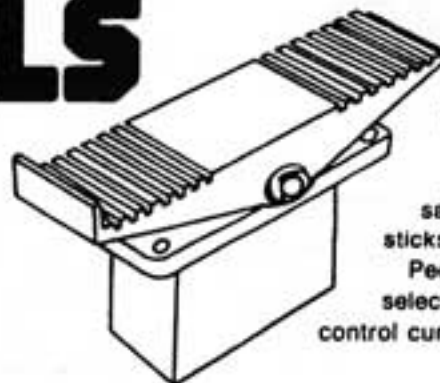

productive environment. The family of "H" Series Controls includes: One Lever units, Two Lever conventional and safety detent controls, Joysticks, Rocker Pedal and Dual Pedal Controls. The proper selection of physical units and control curves solves a wide variety of control problems.

TRANSMISSION CONTROLS

POWERSHIFT

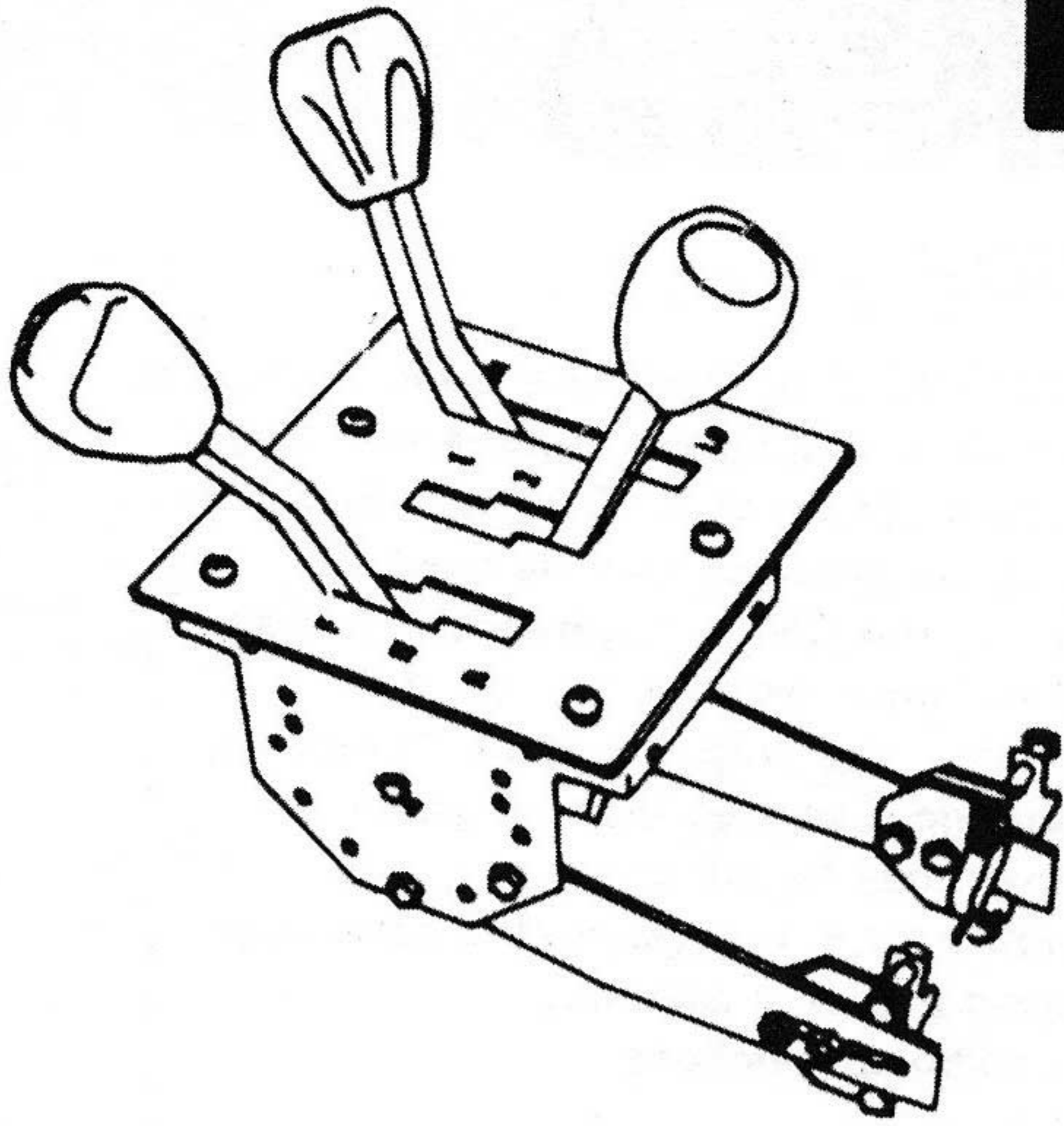

For POWERSHIFT TRANSMISSIONS Quadrastat offers a family of one, two, three and four lever Controls for such functions as Direction, Speed, Hi-Ln Range, and 4 Wheel Disconnect. T13, T25, T29, and T38 Series Controls are available in both standard and special configurations to operate Allison, Clark, Funk, Twin Disc, Warner, and ZF Transmissions. These Controls are ruggedly constructed to meet the demands of the off-highway environment. To complete the installation and insure optimum control, a wide range of Transmission Connector Kits is available.

AUTOMATIC

AUTOMATIC TRANSMISSIONS manufactured by Allison, Chrysler, Ford, GMC, and Warner Gear are typically controlled by QUADCO® T70 Series Controls. The T73 Series Control features precision detents,

positive locking in each range, an illuminated moving red day/night range indicator, and a convenient and attractive pushbutton "T" handle on the input lever.

To assure precise actuation of the Transmission Valve, a complete selection of Transmission Connector Kits is available. Special Controls, such as the Dual Safety Lever Transmission - Throttle Control shown, are readily developed by our Engineering Staff to meet specific industry needs.

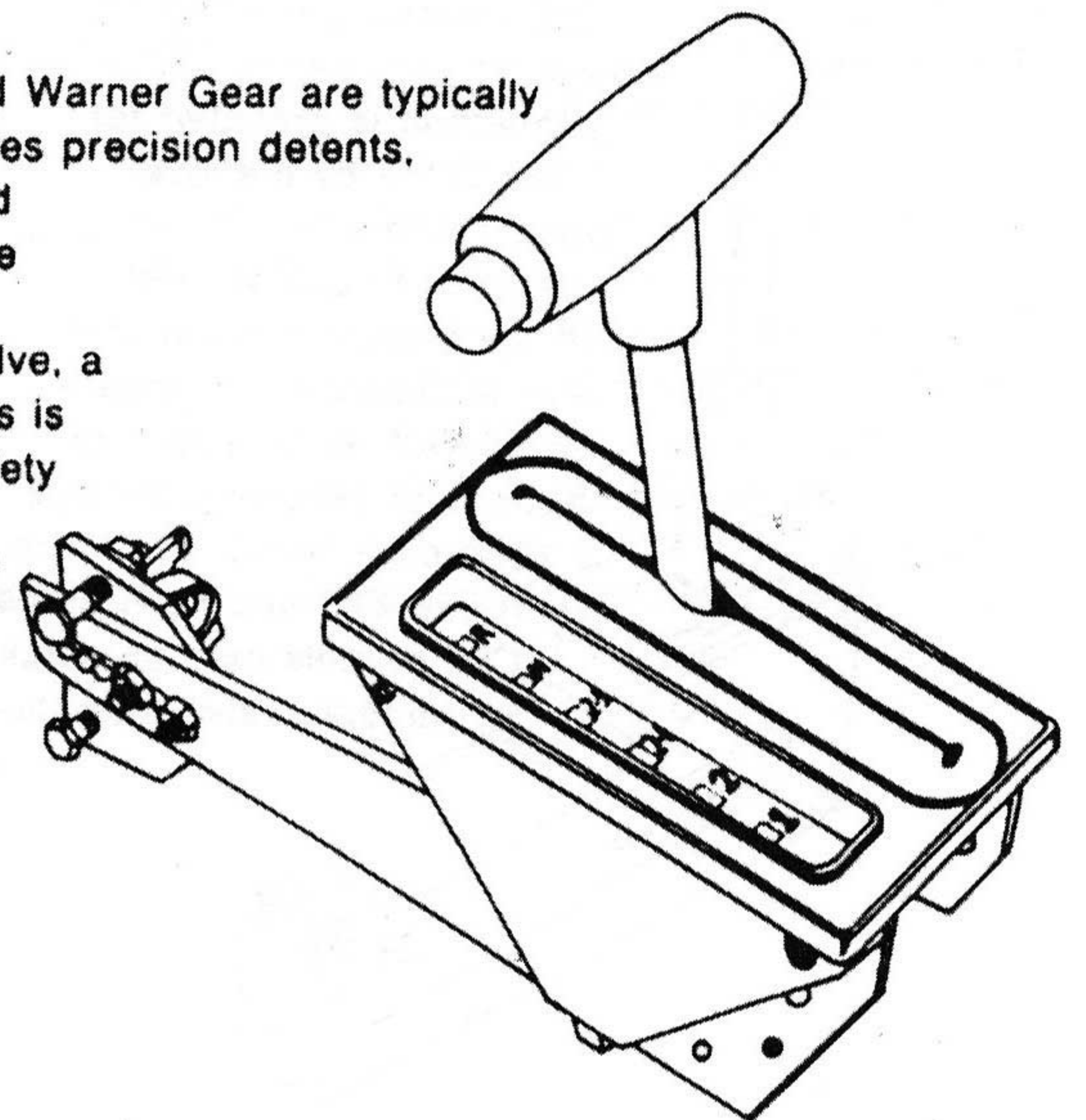
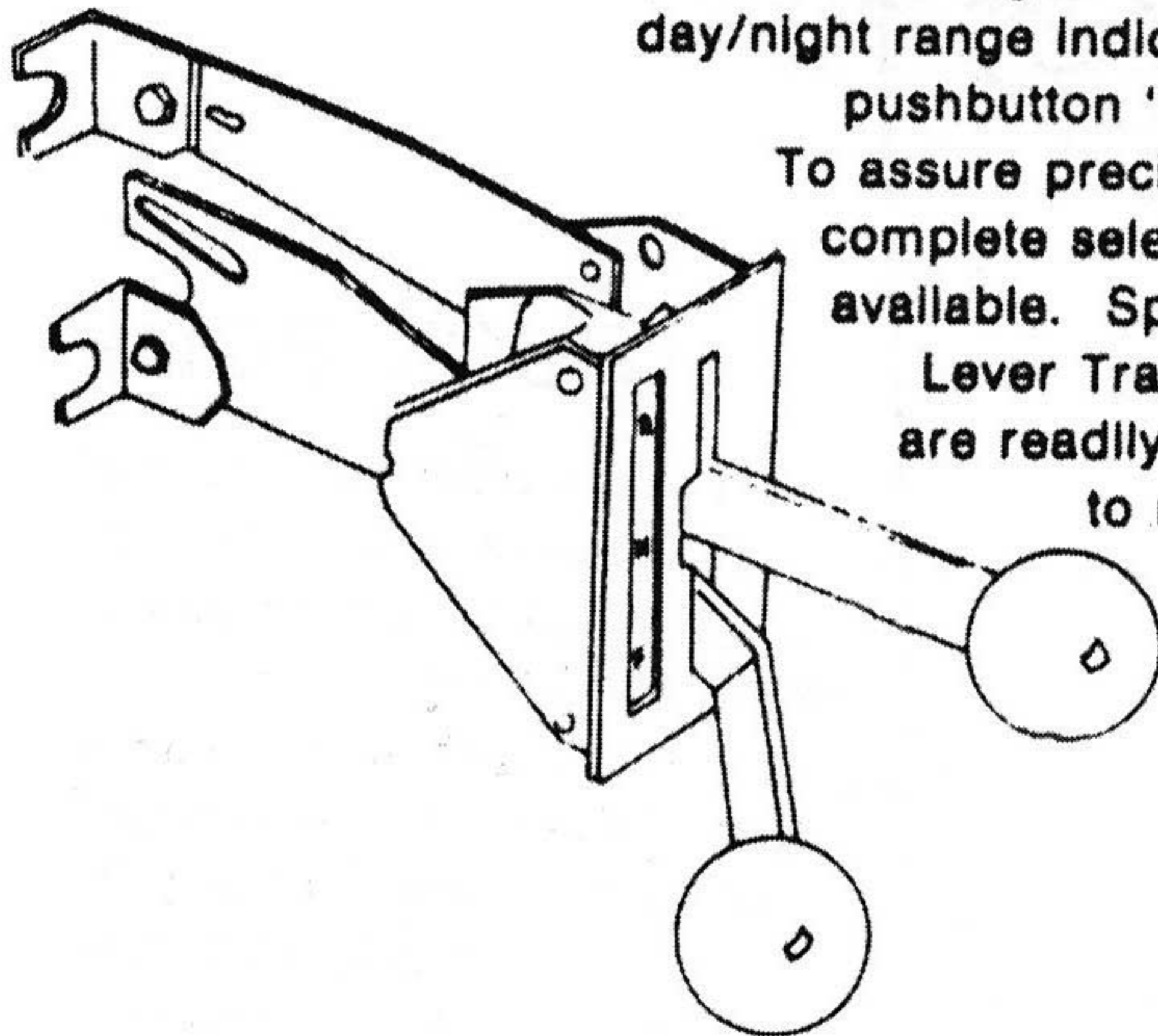

PARKING BRAKE LEVERS

The B40 Series overcenter locking lever is specifically designed to meet the requirements of mechanical parking brakes on both Off and On Highway heavy duty vehicles. The levers

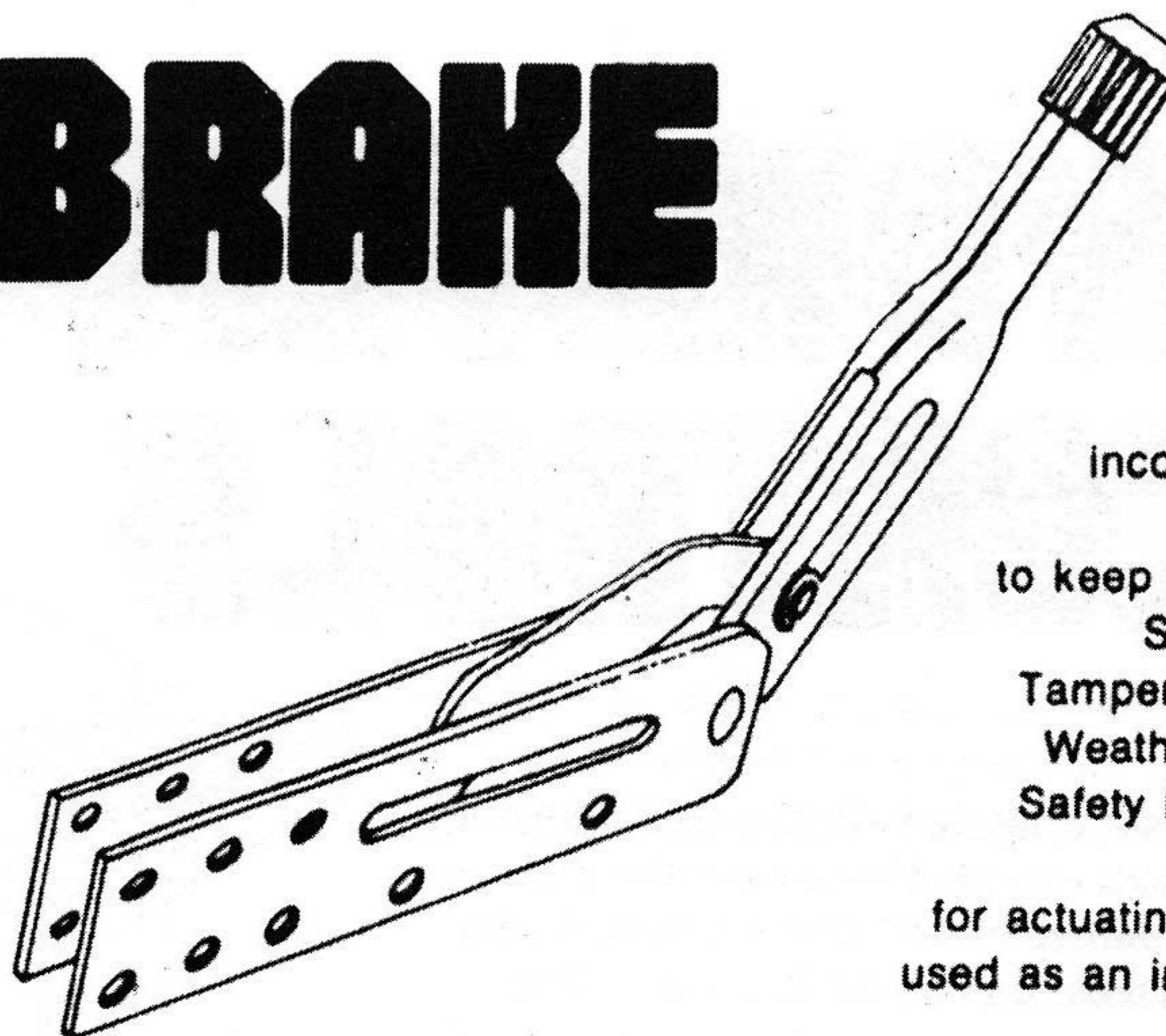

are available for either floor or side mounting. All incorporate an adjustment knob in the handle, an easy way to keep the mechanical linkage taut.

Standard accessories include Tamper Resistant Adjusting Knobs, Weather Resistant "ON" Switches, Safety Latches and Security Locks.

While the lever is normally for actuating parking brakes, it is often used as an inexpensive pull-only throttle or valve control.

P.T.O. or Hoist Single Lever Control

P.T.O. LEVER END DETENT

PART NO.	DESCRIPTION	WEIGHT
BSSPT62	Single lever for 1/4"-28 thd. cables	3.85 lbs.
BSSPT62	Single lever for 1/8"-24 thd. cables	3.85 lbs.

HOIST LEVER CENTER DETENT

PART NO.	DESCRIPTION	WEIGHT
BSSPU62	Single lever for 1/4"-28 thd. cables	3.85 lbs.
BSSPU62	Single lever for 1/8"-24 thd. cables	3.85 lbs.

SINGLE LEVER CONSOLE

PART NO.	DESCRIPTION	WEIGHT
BTS	Black epoxy coated steel console for all B Series single lever controls.	7.60 lbs.

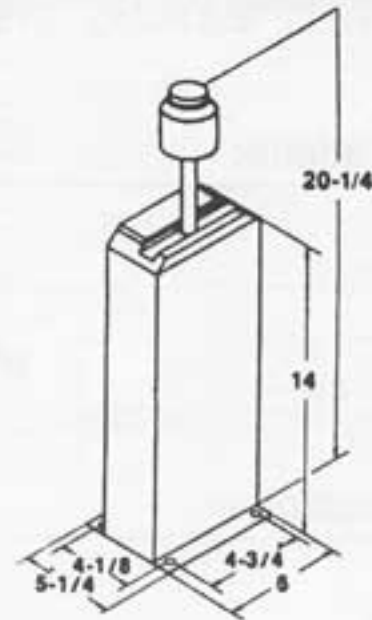

P.T.O.- Hoist Dual Lever Control

P.T.O HOIST DUAL LEVER CONTROL

PART NO.	DESCRIPTION	WEIGHT
BDS52	Dual lever for 1/4"-28 thd. cables	7.5 lbs.
BDS62	Dual lever for 1/8"-24 thd. cables	7.5 lbs.

DUAL LEVER CONSOLE

PART NO.	DESCRIPTION	WEIGHT
BTD	Black epoxy coated steel console for all B Series dual lever controls.	10 lbs.

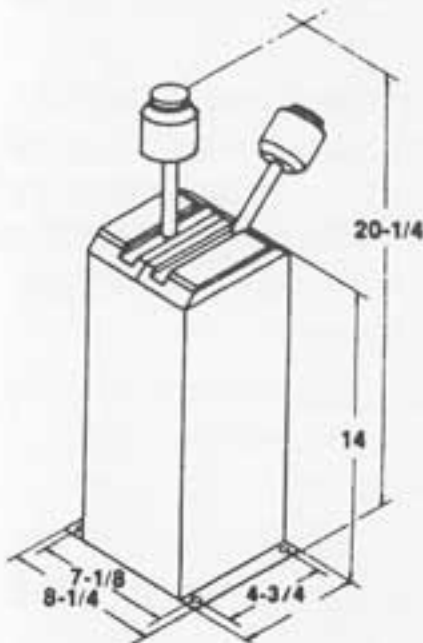

P.T.O.-Hoist-Hoist Triple Lever Control

TRIPLE LEVER CONTROL

PART NO.	DESCRIPTION	WEIGHT
BTTT62	for 1/4"-28 thd. cables	11.5 lbs.
BTTT62	for 1/8"-24 thd. cables	11.5 lbs.

TRIPLE LEVER CONSOLE

PART NO.	DESCRIPTION	WEIGHT
BTT	Black epoxy coated steel console for all B Series triple lever controls.	11.45 lbs.

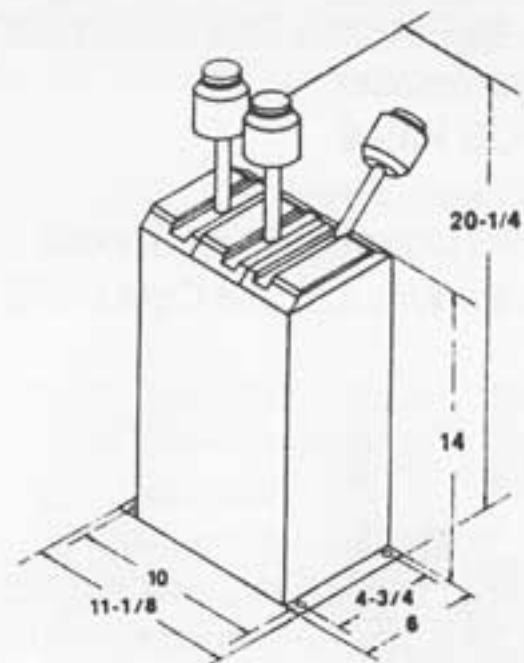

Push-Pull Blue Max™

Marine Applications:

- Shift
- Throttle
- Trim

*Not Intended For Use
as Steering Cable*

Racing Applications:

- Shift
- Fuel Shut Off
- Chute Release
- Throttle

*Not Intended For Use
as Steering Cable*

Features:

- Travel: 3.00"
- Bulkhead type (threaded) conduit caps, stainless steel
- Clamp type (grooved) conduit caps, stainless steel
- 10-32 end rod threads
- BB, BC, CC options are all available
- High temperature

Material:

- 1 x 19 Stainless Steel Wrapped Innermember
- RHOS Rated
- Stainless Steel
- LDPE Covered (Blue) Conduit
- Binder Wire Conduit Core PTFE



Cablecraft Motion Controls' New Blue Max™ cable line is the high performance control cable to solve your push-pull requirements. This superior control is born of aviation engineering design, with extreme low friction and minimal loss of motion. Offering unparalleled performance with the finest, smoothest feel in the industry.

This outstanding design is excellent for long runs with complicated cable routing while being extremely efficient on shorter runs.

Along with a true 4-inch minimum bend radius, lubed for life, and binder wired PTFE core conduit, the outer jacket is resistant to abrasions, gasoline, diesel, and chemicals.

If you are seeing red over your control problems, make the Blue Max high performance line of cables your next move.

High Performance Push-Pull Control Cable

Notes: (Design Parameters)

Travel: 3" minimum

Minimum bend radius: 4.00"

Operating temperature:

from -65°F to +350°F

Slim line grooved conduit cap for marine applications, call for details

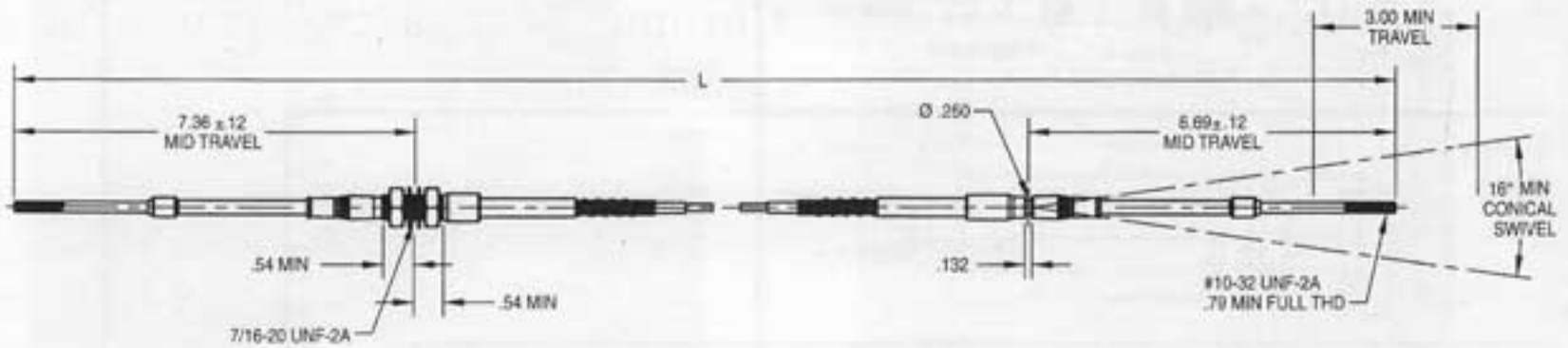

All line art dimensions are represented in inches

High Performance Cable Ordering Codes

795 - 6 - V - TT - 3 - 144

Control Type

*(All End Rods are Stainless Steel)

795 All Exposed Fittings/Parts are Stainless Steel – both ends

796 All Exposed Fittings/Parts are Stainless Steel – one end – Carbon Steel Opposite*

Seal Options

6 Standard

Cable Size

V 10-32 UNF End Rods – Very Light Duty

End Fitting Combinations (TT, TG, GT, GG)

	stainless end		opposite end	
795	T	T	796	T
	T	G		G
	G	G		T
				G

Cable Travel: 3 (inches)

Length +/- .25 (inches)

SPECIALTY CABLES

Choke conversion kit



Chrome T-handle choke cable



Fire bottle cable



SeaDoo cable



Jet ski cable



MARINE DUAL LEVER SIDE MOUNT



MARINE SINGLE LEVER SIDE MOUNT



MARINE DUAL LEVER SYSTEMS

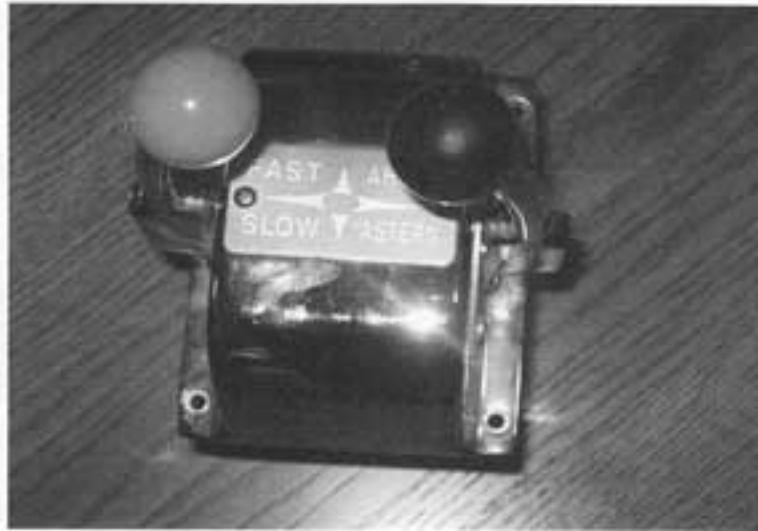

GM CABLE SHIFT LEVER

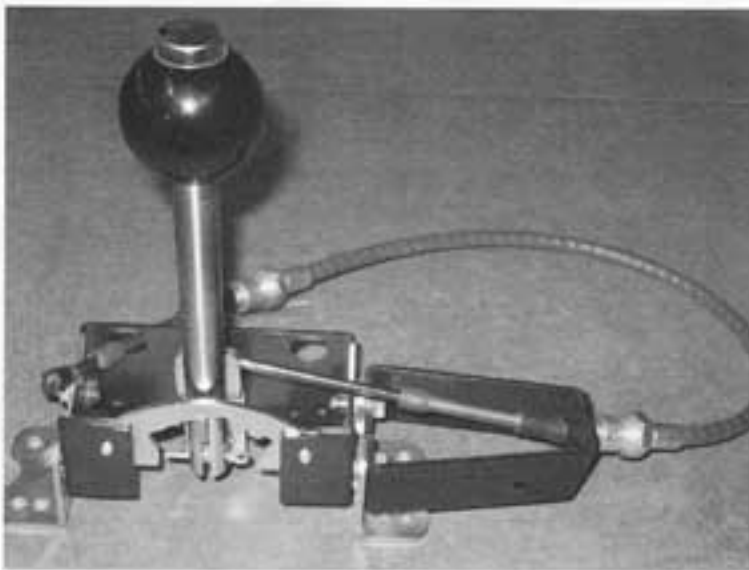

GM SHIFT CABLE



CLEVIS ASSEMBLIES

Includes Pin, Washer and Cotter Pin

PART NUMBER	THREAD	PIN DIA.	LENGTH	INSIDE OPENING	INSIDE DEPTH
175-601-202	10-32 UNF	3/16"	1.56"	.19"	1.00"
175-601-204	10-32 UNF	1/4"	2.00"	.29"	1.30"
175-601-206	1/4-28 UNF	1/4"	2.00"	.29"	1.30"
175-601-210	1/4-28 UNF	5/16"	2.25"	.34"	1.44"
175-601-208	5/16-24 UNF	1/4"	2.00"	.29"	1.30"
175-601-212	5/16-24 UNF	5/16"	2.25"	.34"	1.44"
175-601-216	5/16-24 UNF	3/8"	2.50"	.44"	1.63"
175-601-214	3/8-24 UNF	5/16"	2.25"	.34"	1.44"
175-601-218	3/8-24 UNF	3/8"	2.50"	.44"	1.63"
175-601-222	3/8-24 UNF	7/16"	2.88"	.50"	1.88"
175-601-487	3/8-24 UNF	1/2"	3.00"	.57"	1.88"
175-601-220	7/16-20 UNF	3/8"	2.50"	.44"	1.63"
175-601-226	1/2-20 UNF	7/16"	2.88"	.50"	1.88"
175-601-230	1/2-20 UNF	1/2"	3.00"	.57"	1.88"



Length is from center of pin to end of barrel.

SLIP CLEVIS

PART NUMBER	THREAD	P/N DIAMETER	LENGTH	INSIDE OPENING	INSIDE DEPTH
AC310	1/4-28 UNF	1/4"	3.25"	.28"	2.5"



QUICK DISCONNECT BALL JOINT CONNECTORS

PART NUMBER	STYLE	INTERNAL THREAD	STUD THREAD			
		X	Y	A	B	C
175-403-005	B	NO. 10-32 UNF	1/4-28 UNF	0.88	0.44	0.56
175-403-004	B	1/4-28 UNF	1/4-28 UNF	0.97	0.44	0.56
175-403-003	B	NO. 10-32 UNF	NO. 10-32 UNF	0.88	0.44	0.44
175-403-002	A	5/16-24 UNF	5/16-24 UNF	1.13	0.53	0.69
175-403-001	A	1/4-28 UNF	1/4-28 UNF	0.97	0.47	0.56
175-403-060	A	1/4-28 UNF	5/16-24 UNF	0.97	0.47	0.69
175-403-061	B	5/16-24 UNF	3/8-24 UNF	1.13	0.53	0.87

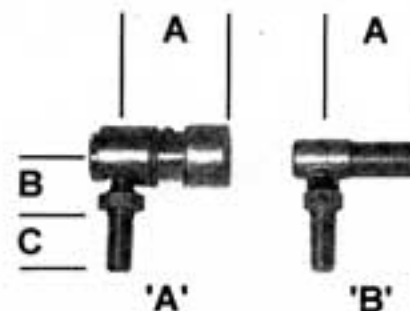

ROD END BEARINGS

PART NUMBER	INTERNAL THREAD	STUD THREAD
175-403-006	5/16-24 UNF x .75	5/16-24 UNF x .68
175-403-009	3/8-24 UNF x .93	3/8-24 UNF x .87
175-403-013	5/16-24 UNF x .93	3/8-24 UNF x .87
175-403-062	1/4-28 UNF x .75	1/4-28 UNF x .56



FEMALE THREADED EYE ENDS

PART NUMBER	INTERNAL THREADS	PIN HOLE	THICKNESS
EE9061	5/16-24	1/4"	.438
EE9069	10-32	1/4"	.344
EE9151	1/4-28	1/4"	.344
185-051-001	5/16-24	9/32"	.250



END ROD THREAD ADAPTERS

PART NUMBER	FROM (INTERNAL)	TO (EXTERNAL)
161-009-001	1/4-28	3/8-28
161-009-003	10-32	5/16-24
161-009-005	1/4-28	3/8-16
161-009-006	5/16-24	3/8-24
161-009-007	10-32	1/4-28



THREADED PIVOTS

PART NUMBER	INTERNAL THREADS	PIN DIA.	MAT'L THICKNESS
161-091-000	10-32	1/4"	1/4"
161-093-001	1/4-28	1/4"	1/8"
161-093-002	1/4-28	1/4"	1/4"
161-093-003	1/4-28	1/4"	5/16"



WIRE STOP/PIVOT

PART NUMBER	WIRE	PIN DIA.	MAT'L THICKNESS	SET SCREW
160-450-001	.075"	1/4"	3/16"	10-32 UNF
160-450-002	.075"	1/4"	5/16"	10-32 UNF





VLD/LD Mounting (fits grooved conduit fitting)

Part Number

ST3652



Strap Clamps and Shims

Use With	Strap	Shim
VLD	161-011-001	175-435-050
LD	161-011-002	175-435-051

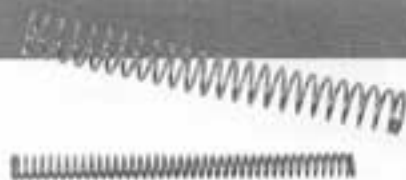

Compression Springs (for brake cables)

Part Number	Inside Dia.	Outside Dia.	Length	Solid Height	Spring Rate
175-923-001	.30	.437	12.0	4.60	3.93 lb/inch
175-923-002	.30	.437	6.4	3.20	5.75 lb/inch
175-923-006	.30	.437	5.7	2.87	6.23 lb/inch
175-924-001	.26	.437	10.0	6.62	15.97 lb/inch
175-925-003	.40	.500	4.3	1.00	4.47 lb/inch



Bellows (trim to length)

Adapter Ring

Part Number	For Use With Cable Size
175-435-072	VLD
175-435-081	LD
175-435-082	MD

Part Number	For Use With Cable Size	Compressed Length	Extended Length	Max Travel
175-522-001	VLD	3.0"	8.0	6.0"
175-524-002	LD	3.4"	9.7	6.0"
175-525-001	MD	4.5"	11.3	6.0"

Maximum recommended is shown.
Must be trimmed shorter for use on shorter travel cables.
See cutting matrix #CC-111. Adapter rings to mount bellows to conduit fittings.



Spring Return Kit

Convert any LD size, 2" travel threaded swivel end to spring loaded to extended position.
Force with end rod extended - 4.6 lb
Force with end rod retracted - 15.2 lb

Part Numbers	
Spring	175-930-001
Collar	175-435-118
Outer Guide	160-071-025



Umbrella Seal

Part Number	For Use With Cable Size
160-071-005	VLD, 2"
160-071-006	VLD, 3"
160-071-007	VLD, 4"
160-071-008	LD, 2"
160-071-009	LD, 3"
160-071-010	LD, 4"
160-071-011	MD, 2"
160-071-012	MD, 3"
160-071-013	MD, 4"

SPECIALTY HARDWARE

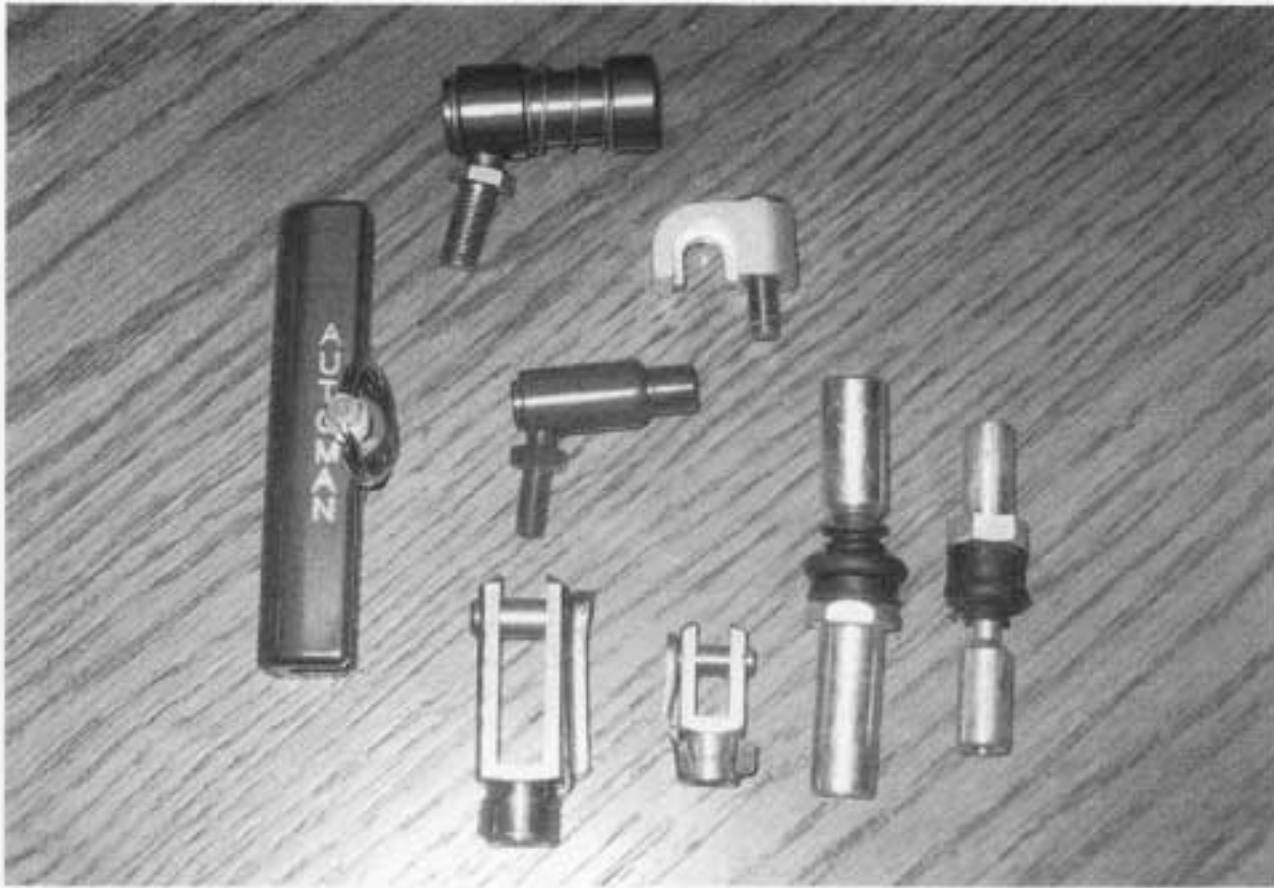

ACCESSORY HARDWARE



Control Cable Cautions & Warnings

The following cautions describe application and installation information.

1. Do not install control cables on any application which may exceed any of the design parameters of the control cable.
2. Cablecraft control cables are designed and assembled to be non-repairable. Do not attempt to modify this control cable.
3. Cablecraft cables are designed to be contaminant resistant; not contaminant proof. Protect the cable from contaminants such as gas, oil, diesel fuel, water, dirt and chemicals which may damage the control cable.
4. Protect the control cable from physical damage by paint, kinking, vibration, etc., which may damage the control cable.
5. Control cables have the best load capacity in the **pull** mode. Always install the control cable so it **pulls** the greatest load, and **pushes** the smaller load; and **pulls** the item into the neutral or "off" position.
6. Do not install the control cable with the power on or the engine running. Serious injury or death could result.
7. The swivel angle must be centered within the available swivel angle.

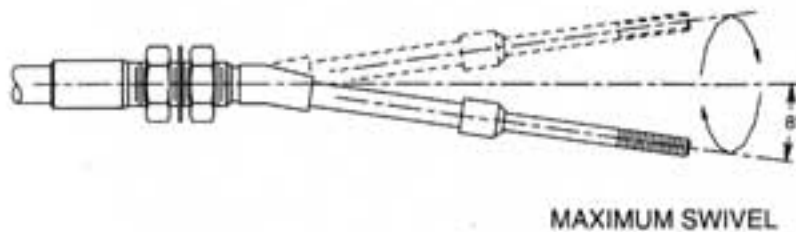

8. The usable stroke must be centered within the available travel:

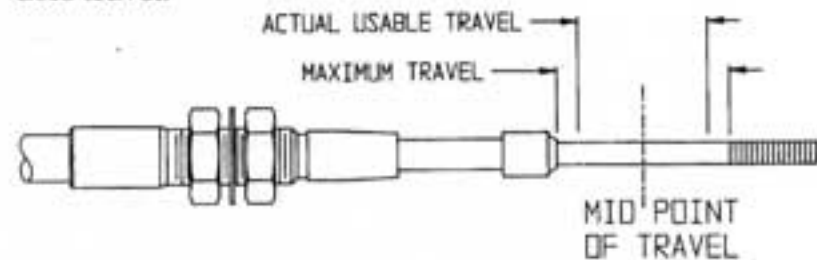

The following warnings describe important push-pull cable operation and maintenance information.

1. Do not adjust the control cable with the power on or the engine running. Serious injury or death could result.
2. A gradual or sudden increase in the no-load friction (cable disconnect at both ends) of a control cable is an indication of a pending or present performance problem. The control cable should be replaced, otherwise serious injury or death may result.
3. A gradual or sudden decrease in the usable stroke, is an indication of a pending or present performance problem. The control cable should be replaced, otherwise serious injury or death may result.
4. Control cables which have moisture inside of them and/or have frozen should be replaced. Do not apply heat to thaw or dry control cables.
5. Cablecraft control cables are lubricated for the life of the control cable. Do not remove the seal or lubricate the control cable.
6. Cablecraft control cables are designed to be non-repairable. Do not attempt to repair this control cable.

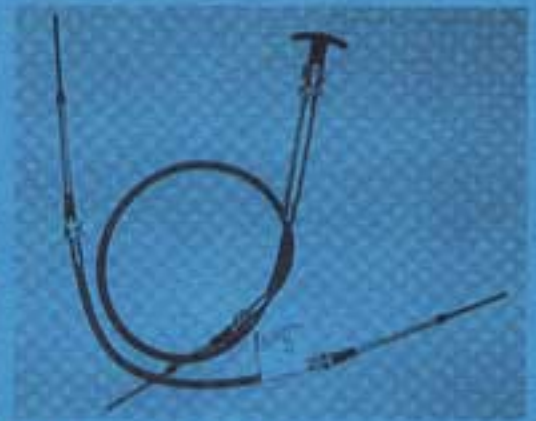
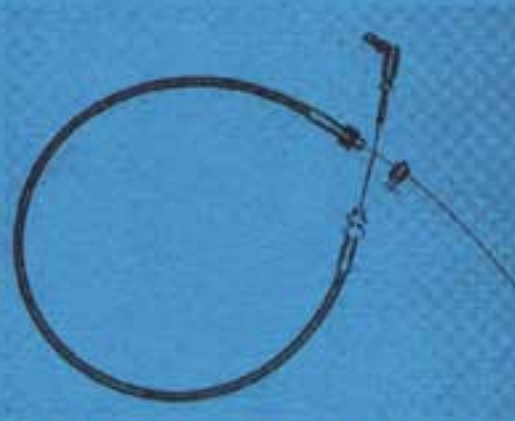

CALIFORNIA PUSH-PULL, INC.

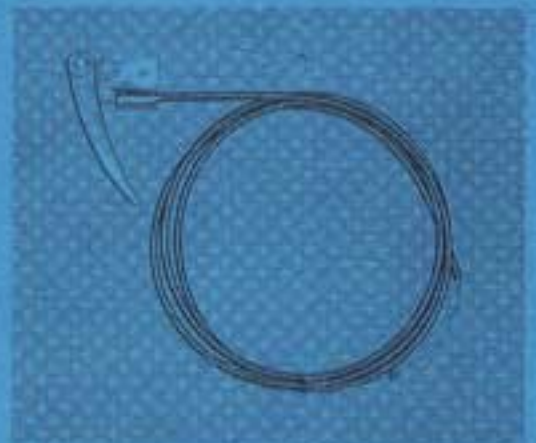
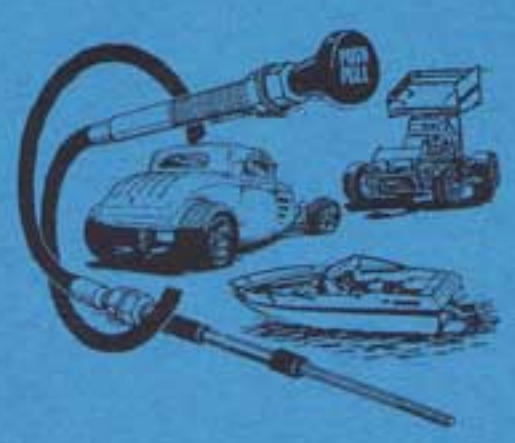

We are a custom cable house, and stock various control cable components. We are able to build any type, size or length cable to meet your requirements.

Our throttle and shift cables are highly flexible and of heavy duty construction for long life under rugged conditions. All end rods and support tubes are stainless steel and all components are swagged on for strength.

Our brake cable division uses only true OEM style flat wound lined housing. All components are swagged, not set screwed. Our brake cables are made to your specifications, we can build your cable from a drawing or old sample.

We have a line of specialty cables such as parachute, trim to length throttle and more.

We stock a full line of accessories, from adjustable clevises, quick release ball joints, rod ends, cable clamps and much more.

Give us a sample, drawing or print of the cable you need and we will supply you with that cable.

For more information - Call 530-893-4060 or Fax 530-893-4062

Website: www.push-pull.com • E-mail: info@push-pull.com

 CALIFORNIA PUSH-PULL INC.

